

Serial 000-06118

DEPT

and 000-06092 ← (NEW TUBES 3/19/79
(0A2, 0B2, 6X4, 5.763 only)

INSTRUCTION MANUAL
FOR THE
Q METER TYPE 260-A



BOONTON RADIO COMPANY

Green Pond Road

Rockaway, New Jersey

U. S. A.

INSTRUCTION MANUAL
FOR THE
Q METER TYPE 260-A



BOONTON RADIO COMPANY

Green Pond Road

Rockaway, New Jersey

U. S. A.

TABLE OF CONTENTS

Section	Page
I. DESCRIPTION	
A. General Description	7
B. Panel Layout and Controls	7
C. Measuring-Circuit Connection Terminals	7
D. Power Sources	7
II. SPECIFICATIONS	
A. Frequency	7
B. Q Measurements	8
C. Difference (ΔQ) Measurements	8
D. Internal Resonating Capacitor	8
E. Effective Inductance Measurements	8
F. Tubes	8
G. Power Source	8
H. Dimensions	8
I. Weight	8
III. OPERATING INSTRUCTIONS	
A. General	8
B. Installation	8
C. Operating Precautions	9
D. Methods of Connecting Components	
1. Direct Connection	9
2. Parallel Connection	9
3. Series Connection	10
E. Operating Procedures	
1. Initial Adjustments	10
2. Q Measurements (Direct Connection)	10
3. ΔQ Measurements	11
4. Inductance Measurements (Direct Connection)	11
F. Low Frequency Measurements	11
IV. PRINCIPLE OF OPERATION	
A. General	12
B. Q Meter Theory	12
C. Residual Circuit Parameters	12

Continued on following page

TABLE OF CONTENTS—Continued

Section	Page
V. SOURCES OF ERROR	
A. Insertion Resistance	12
B. Residual Inductance	13
C. Q Voltmeter Conductance	13
D. Correlation of Q	14
VI. MAINTENANCE	
A. General	14
B. Removing the Instrument from Its Cabinet	15
C. Replacement of Tubes	15
D. Replacement of Thermocouple Assembly	16
E. Adjustment and Calibration	17
F. Power Supply Check	18
G. Trouble Shooting	19
APPENDIX	
A. Nomenclature	19
B. Distributed Capacitance	19
C. Parallel Measurements	21
D. Series Measurements	24
E. Correction of Errors	25
BIBLIOGRAPHY	28
ELECTRICAL COMPONENTS	30

LIST OF ILLUSTRATIONS

		Page
Figure I-1	Front View of Q Meter Type 260-A.....	6
Figure III-1	Direct Connection to Measuring Circuit.....	9
Figure III-2	Parallel Connection to Measuring Circuit.....	9
Figure III-3	Series Connection to Measuring Circuit.....	10
Figure III-4	Low Frequency Q Voltmeter Correction.....	12
Figure IV-1	Basic Measuring Circuit.....	12
Figure IV-2	Equivalent Measuring Circuit (Approximate).....	12
Figure V-1	Circuit Q Correction Guide for Insertion Resistor Error	13
Figure V-2	Typical Curve of Q Voltmeter Input Resistance vs. Frequency	14
Figure VI-1	Resonating Capacitor, Q Voltmeter Tube, and Thermocouple Assembly	15
Figure VI-2	Oscillator Compartment Showing Tube and Calibra- tion Adjustment Capacitor.....	16
Figure VI-3	Power Supply Chassis Showing Q Voltmeter Calibra- tion Adjustments	17
Figure VI-4	Location of Injection Circuit Connecting Strap....	17
Figure VI-5	Q Voltmeter Calibration Circuit.....	18
Figure A	Typical Variation of Effective Q and Inductance with Frequency	20
Figure B	Correction Chart for Distributed Capacitance.....	20
Figure C	Using the LC Dial to Determine True Inductance...	21
Figure D	Ranges of Measurable Resistance.....	22
Figure E	Apparent Capacitance and Conductance of Two RF Chokes in the Vicinity of Self-Resonance.....	23
	Schematic Diagram	35

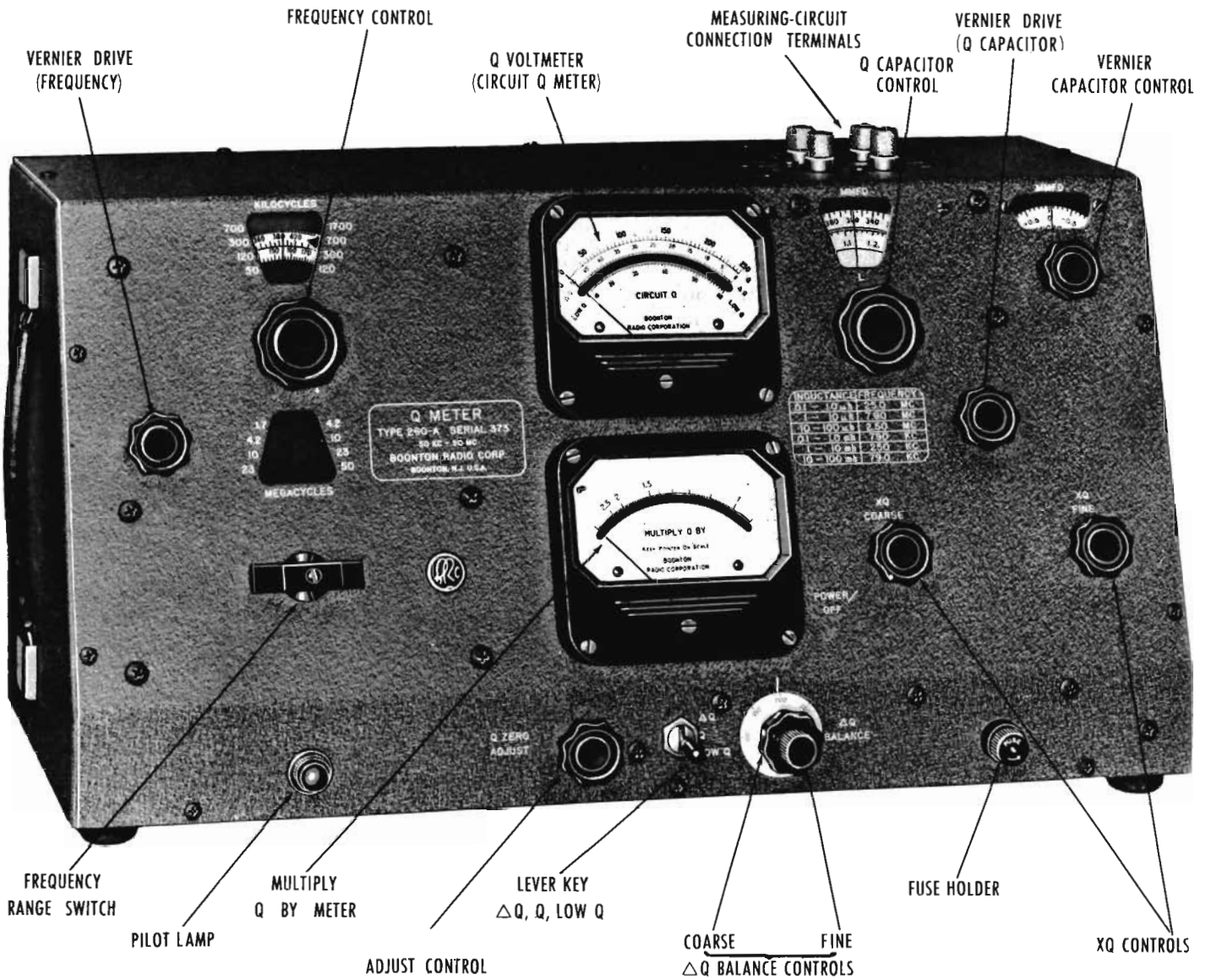

Figure I-1 Front view of Q Meter Type 260-A

SECTION I

DESCRIPTION

A. GENERAL DESCRIPTION.

The Q Meter Type 260-A measures the Q of inductors directly from 10 to 625 over a frequency range of 50 KC to 50 MC. Values of inductance from 0.09 microhenries to 130 millihenries can also be measured directly with this instrument. Front panel dials which indicate the frequency of the applied voltage and the capacitance of the measuring circuit permit the calculation of inductance outside this range as well as values of Q, X, R, and L or C of other components.

B. PANEL LAYOUT AND CONTROLS.

A front view of the instrument appears in Figure I-1 which shows the various controls, meters, and measuring-circuit terminal posts. The CIRCUIT Q meter is centrally located and has three scales: Q, ΔQ , and LOW Q. The LOW Q scale expands the lower portion of the Q scale for values of Q from 10 to 60. The ΔQ scale reads directly the change in Q between two circuit conditions ($\Delta Q = Q_1 - Q_2$). The range of this scale, 0 to 50, is intentionally limited so that small changes of Q can be accurately measured.

Immediately below the CIRCUIT Q meter is the MULTIPLY Q BY meter. Its readings are set by the XQ COARSE and XQ FINE controls located to the right of the meter. These controls adjust the oscillator output, hence the injection voltage in the measuring circuit. Readings on all scales of the CIRCUIT Q meter must be multiplied by the value indicated on the MULTIPLY Q BY meter to obtain the actual values.

Both CIRCUIT Q and MULTIPLY Q BY meters have a wide-mirrored arc for parallax correction.

The lower section of the instrument panel contains a pilot lamp, Q ZERO ADJUST control for the CIRCUIT Q meter, spring-return lever key which selects one of three scales on the CIRCUIT Q meter, concentric controls for ΔQ BALANCE which permit zeroing the meter on the ΔQ scale, and a fuse holder.

The XQ COARSE control, in its extreme counter-clockwise position, actuates the POWER switch.

The FREQUENCY RANGE switch and companion FREQUENCY CONTROL dial are located on the left side of the front panel. Eight bands completely cover the frequency range from 50 KC to 50 MC. The vernier drive knob for the FREQUENCY CONTROL dial is to the left of the dial.

On the right side of the panel are the RESONATING CAPACITOR and VERNIER CAPACITOR dials,

covering a capacitance range of 30 $\mu\mu\text{f}$ to 460 $\mu\mu\text{f}$ and 0 to $\pm 3.0 \mu\mu\text{f}$, respectively. The vernier drive knob for the RESONATING CAPACITOR dial is just to the right of the INDUCTANCE-FREQUENCY chart.

C. MEASURING-CIRCUIT CONNECTION TERMINALS.

Four binding-post terminals on top of the instrument provide facilities for connecting unknown components to the measuring circuit. Inductors which resonate with the RESONATING CAPACITOR within the frequency range of the Q Meter Type 260-A, may be measured by connecting them to the COIL terminals. Other components are generally measured in conjunction with an auxiliary work coil. Small inductors, large capacitors, and low impedance components should be connected in series with the work coil, while small capacitors, large inductors, and components of high impedance are to be connected across the CAP terminals. Connecting an unknown component to the measuring circuit usually requires retuning the circuit. The parameters of the unknown component may be calculated by noting the magnitudes of the changes.

A set of Inductors, Type 103-A, is available for use with the Q Meter Type 260-A. These specially constructed coils serve as work coils and also allow periodic checks of instrument operation.

Q-Standards Type 513-A and 518-A are available for testing the Q calibration of the instrument.

D. POWER SOURCES.

The Q Meter Type 260-A may be used *only* with a 60-cycle a-c power source and provides internal stabilization of a-c line voltage, which spares the user the inconvenience of oscillator output variations and slight changes of electrical zero set.

The Q Meter Type 260-AP, available on special order, may be used with an a-c power source of 50 or 60 cycles, in conjunction with an external voltage stabilizer.

SECTION II

SPECIFICATIONS

FREQUENCY RANGE:

Continuously variable from 50 kilocycles to 50 megacycles in eight self-contained ranges.

FREQUENCY ACCURACY:

Approximately $\pm 1\%$.

RANGE OF CIRCUIT Q MEASUREMENT:

Q Measurements can be made from 10 to 625. Range of ΔQ scale is from 0 to 50.

ACCURACY OF Q MEASUREMENT:

Circuit Q of 250 read directly on the indicating meter is accurate to $\pm 5\%$ from 50 kc. to 30 mc.; accuracy decreases to $\pm 10\%$ at 50 mc.

CAPACITANCE OF INTERNAL CALIBRATED CONDENSER:

30 to 460 mmf. (direct reading) calibrated in 1.0 mmf. increments from 30 to 100 mmf: 5.0 mmf. increments from 100 to 460 mmf.

ACCURACY:

Approximately 1% or 1.0 mmf., whichever is greater. Range of Vernier capacitance dial is -3.0 to +3.0 mmf. (direct reading) calibrated in 0.1 mmf. increments.

Accuracy ± 0.1 mmf.

EFFECTIVE INDUCTANCE MEASUREMENTS:

0.09 uh to 130 mh (direct reading) at six specific frequencies. Accuracy: Approx. $\pm 3.0\%$ for resonating capacitance. ≥ 100 mmf.

SPECIAL FEATURES:

Operation down to 1 kc. with external oscillator and coupling transformer Type 564-A. Expanded sensitivities provided by "Lo Q" and " Δ Q" scales. Thermocouple overload protection for normal operation.

Internally regulated.

ACCESSORIES:

Furnished: None

Available: 564-A Coupling Transformer
103-A Type work coils
513-A Q Standard

TUBE COMPLEMENT:

1 — 535-A
1 — 5763
1 — 6X4
1 — OB2
1 — OA2

POWER REQUIREMENTS:

Power Supply: 95-130 volts — 60 cps only (internally regulated); power consumption is 65 watts, Model 260-AP available for 95 to 130 volts, 50 cps only. State voltage required in your order. Power consumption is 65 watts.

SIZE:

Height: 12 $\frac{1}{2}$ ", Width: 20", Depth: 8 $\frac{1}{2}$ "

WEIGHT:

260-A
40 lbs. net
98 lbs. gross packed for export
55 lbs. gross packed for domestic
50 lbs. legal weight packed for export

260-AP

40 lbs. net
98 lbs. gross packed for export
55 lbs. gross packed for domestic
50 lbs. legal weight packed for export

**SECTION III
OPERATING INSTRUCTIONS**

A. GENERAL.

The direct measurement of Q and inductance is described in this section, as well as the procedure for connecting other components to the measuring circuit.

The Q Meter Type 260-A requires the connection of an inductor to the COIL terminals to complete the measuring circuit. This circuit may then be tuned to resonance, either by setting the oscillator to a given frequency and varying the internal resonating capacitor, or by presetting the resonating capacitor to a desired value and adjusting the frequency controls. Resonance is evidenced by a maximum deflection of the CIRCUIT Q meter.

The *indicated* Q (which is the resonant reading on the CIRCUIT Q meter) is called the *circuit* Q because the losses of the internal resonating capacitor, Q voltmeter, and insertion resistor are all included in the measuring circuit. To avoid ambiguity, the *circuit* Q, as read on the Q Meter, will be called *indicated* Q throughout the remainder of this book. The *effective* Q of the measured inductor will be somewhat greater than the *indicated* Q. The difference can generally be neglected. In certain cases, however, the Q readings may require correction. This is considered in greater detail in Section V.

B. INSTALLATION.

Make certain that the supply voltage and frequency of the a-c power source corresponds with the values shown in Section II, or on the instrument.

To improve stability and prevent overloading the CIRCUIT Q meter whenever the HI terminals of the measuring circuit are touched by the operator's hands, the Q Meter should be well grounded. The binding post on the back of the cabinet is provided for this purpose.

If it is necessary, adjust the mechanical zero of the CIRCUIT Q meter and the MULTIPLY Q BY meter.

Plug the line cord into a suitable receptacle and apply power by turning the XQ COARSE control clockwise from its OFF position just far enough to actuate the switch. CAUTION: Do not turn this control fully clockwise or the thermocouple may be overloaded when the oscillator warms up. Allow about one minute to elapse before proceeding.

The XQ COARSE control should then be advanced clockwise until a reading is obtained on the MULTIPLY Q BY meter. This indicates that the internal oscillator is functioning and providing power to the measuring circuit.

C. OPERATING PRECAUTIONS.

When the Q Meter is first received, it is suggested that careful measurements be made using BRC Q-Standards Type 513-A and 518-A, or a set of Inductors Type 103-A, and the data be recorded and filed. At least one measurement should be made near each end of each inductor frequency band. These recommended measurements provide data for each individual Q Meter which will be available for reference and comparison should it ever become necessary to perform maintenance work on the instrument. Only data obtained with Q-Standards Type 513-A and 518-A should be relied on for instrument recalibration.

Routine measurements may be made with the Q Meter a few minutes after turning on the power. A warm-up time of at least one hour is desirable before making precision measurements. When components are measured in conjunction with work coils, the work coils should be well shielded. The possibility of error which may result from coupling between the work coil and the component is thereby eliminated. Inductors Type 103-A are well suited for this application.

The LO post of the COIL terminals is not at ground potential. Signal voltage from the internal oscillator is injected into the measuring circuit between this point and ground. Components which are grounded, therefore, cannot be measured at the COIL terminals. Care should be taken that components under test are not accidentally grounded to the instrument case.

The MULTIPLY Q BY meter derives its voltage from a thermocouple which monitors the signal voltage injected into the measuring circuit. Since it is possible to damage the thermocouple, it is necessary to restrict the XQ meter to on-scale deflections. While the output of the internal oscillator is held reasonably constant over the entire frequency range of the instrument, some variation must be expected. The greatest danger of thermocouple burnout, therefore, occurs when the frequency range switch is changed, or, when searching for a condition of resonance with the frequency control. Thermocouple damage can be prevented by establishing a practice of lowering the MULTIPLY Q BY meter deflection to about mid-scale before shifting the oscillator frequency.

The recessed areas surrounding the measuring circuit terminal posts should be examined frequently for wire clippings and dirt particles. Foreign material accumulated in these wells should be removed since it may reduce the measured Q and possibly short the measuring circuit.

D. METHODS OF CONNECTING COMPONENTS.

There are three basic methods of connecting components to the measuring circuit of the Q Meter. The

nature and magnitude of the impedance to be measured usually dictates the method of connection.

1. DIRECT CONNECTION.

Most coils can be measured by connecting them directly to the COIL terminals, as shown in Figure III-1. The measuring circuit is resonated by adjusting either the capacitance or frequency. The indicated Q is read on the CIRCUIT Q meter.

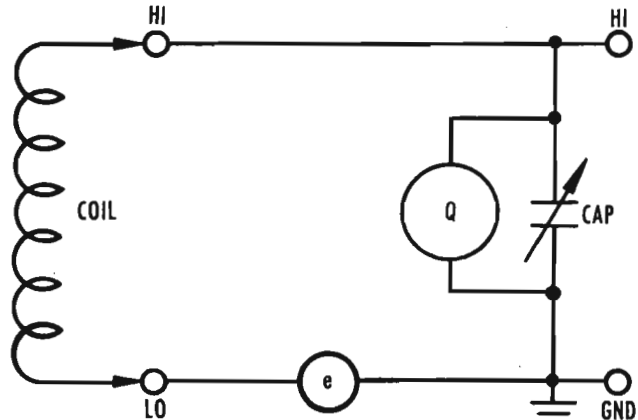

Figure III-1 Direct connection to measuring circuit

If one of the frequencies designated on the front panel INDUCTANCE-FREQUENCY chart is used, the effective inductance of the coil may be read on the L scale of the resonating-capacitor dial. For frequencies other than those specified on the chart, the inductance of the coil can be calculated using indicated values of frequency and capacitance.

2. PARALLEL CONNECTION.

High impedance components, such as high-value resistors, certain inductors, and small capacitors, are measured by connecting them in parallel with the CAP terminals. This connection is shown in Figure III-2. Before the unknown component is connected, however, the measuring circuit must be resonated, using a stable work

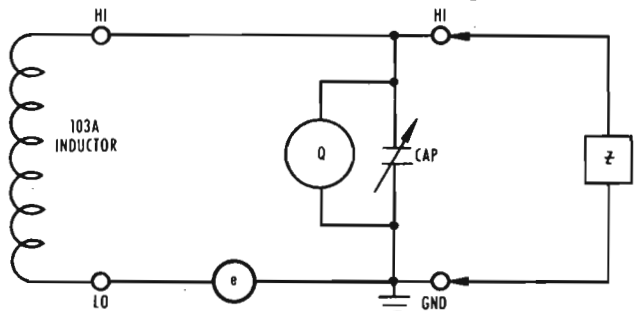

Figure III-2 Parallel connection to measuring circuit

coil (such as an Inductor Type 103-A) to establish reference values of Q and C. Then, when the component under test is connected to the measuring circuit and the capacitor is readjusted for resonance, the altered values of Q and C can be combined with the reference values in equations which yield the parameters of the unknown specimen. These measurements, as well as those described in Section D-3, which follows, are discussed in the Appendix.

3. SERIES CONNECTION.

Low impedance components, which include low value resistors, small coils, and large capacitors, are measured in series with the measuring circuit. Figure III-3 shows this connection. The component to be measured is placed in series with a work coil between the LO terminal and the low-potential end of the work coil. A heavy shorting strap, as illustrated, should be used to

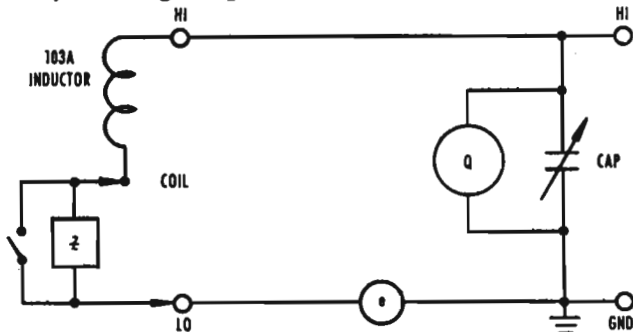

Figure III-3 Series connection to measuring circuit short-circuit the unknown component while a reference condition is established. The strap is then opened, or removed, and the measuring circuit re-resonated. This procedure permits the component under test to be physically connected even though it is electrically out of the circuit, and eliminates possible errors by maintaining the relative positions of the work coil and unknown component.

Simple but effective measuring jigs can be constructed for production testing which provide facilities for connecting and shorting the specimen and for holding the reference coil.

The reference and altered values of Q and C may be combined in suitable equations (see Table I in the Appendix) to calculate the parameters of the unknown component.

E. OPERATING PROCEDURES.

1. INITIAL ADJUSTMENTS.

In making the following adjustments, observe the precautions outlined in Section III-C. The various controls are described in Section I-B. and shown in Figure I-1. Preliminary adjustment of these controls is as follows:

- a. Check, and if necessary, adjust the mechanical zeroes of both meters.
- b. Turn the POWER OFF switch on. The XQ COARSE control should be turned only enough to actuate the switch.
- c. Allow a few minutes for the instrument to warm up. For precision measurements, the warm-up period should be at least one hour.
- d. It is necessary to adjust the zero of the Q voltmeter in the absence of a resonant rise of the injection voltage. To do this, connect a coil to the COIL terminals to provide a low resistance path for the Q voltmeter, making certain the coil selected is not close to resonance. If the reading on the CIRCUIT Q meter changes when

either the frequency or capacitance is varied, shift to a higher or lower frequency, or detune the circuit with the resonating capacitor control.

e. Using the Q ZERO ADJUST potentiometer, zero the CIRCUIT Q meter needle. Depressing the lever key to LOW Q increases the meter sensitivity and permits the zero to be set more accurately. The accuracy may be further checked by alternating the lever key between the Q and LOW Q positions. The setting is correct if the needle remains stationary at zero.

The instrument is now ready for use.

2. Q MEASUREMENTS (DIRECT CONNECTION).

The following procedure can be used to measure directly the Q of coils connected to the COIL terminals.

a. Connect the coil to be measured to the COIL terminals (after completing "Initial Adjustments"). Figure III-1 illustrates this connection.

b. Set the frequency range switch to the proper band and adjust the frequency control to the desired frequency.

c. Using the XQ controls (COARSE and FINE), adjust the MULTIPLY Q BY meter to read 1.0.

d. Resonate the coil by adjusting the resonating capacitor control for maximum deflection of the CIRCUIT Q meter. Alternatively, the resonating capacitor control may be set to a desired value and the measuring circuit resonated by adjusting the oscillator frequency.

e. Read the indicated Q on the top (Q) scale of the CIRCUIT Q meter.

f. If the Q reading is less than 60, depress the lever key to the LOW Q position, readjust for resonance and read the LOW Q scale.

g. When the circuit Q is greater than 250, the meter will deflect off scale. If this happens, readjust the MULTIPLY Q BY meter with the XQ controls to a suitable multiplying factor which will allow the CIRCUIT Q meter to be read, preferably on the upper third of its scale.

Note: The final adjustment for resonance can be made with greater ease, for high-Q coils, by using the vernier capacitor. The total circuit capacitance is then obtained by adding or subtracting the vernier dial reading to or from the reading on the main capacitor dial as indicated by the sign on the vernier dial.

b. To calculate the effective series resistance of the coil being measured, substitute the values of Q, C, and ω in the equation,

$$R_s = 1/\omega C Q \quad (\text{ohms}) \quad (3.1)$$

where $\omega = 2\pi$ times the frequency in cycles-per-second

C = measuring circuit capacitance in farads

Q = indicated Q

If very accurate measurements are required, refer to Section V and the Appendix for corrections which may be applied.

3. ΔQ MEASUREMENTS.

Measurements are described in the Appendix which require a knowledge of a change of *indicated* Q. If the two values of Q are nearly identical, the difference is difficult to read accurately on the normal Q scale. ~

The ΔQ feature of the Q Meter Type 260-A provides a direct-reading scale for these differences of Q's. The scale is calibrated from 0 to 50 (from right to left) and readings should be multiplied by the setting on the MULTIPLY Q BY meter. Delta (Δ) Q is measured as follows:

a. Resonate the measuring circuit with only the work coil in the circuit. Mentally note the value of Q_1 .

b. Set the ΔQ coarse control (outer knob) and its attached dial to the approximate value of Q_1 . Lift the lever key to the ΔQ position and adjust the fine ΔQ BALANCE control (center knob) for a meter reading of zero on the ΔQ scale (full scale deflection). Recheck the tuning with the lever key in this position for exact resonance (as indicated by a maximum deflection to the right) and, if necessary, reset the ΔQ zero.

c. Release the lever key and make the desired circuit change. Restore resonance to the circuit and again lift the lever key to the ΔQ position. Carefully recheck the tuning for resonance (maximum meter deflection) and read the change in Q on the ΔQ (red) scale. This value of ΔQ must be multiplied by the reading on the MULTIPLY Q BY meter. Release the lever key before making other changes.

If the change in Q exceeds the limit of the scale, the difference should be calculated arithmetically from the two Q values, namely, $\Delta Q = Q_1 - Q_2$.

4. INDUCTANCE MEASUREMENTS (DIRECT CONNECTION).

The following procedure can be used to measure directly the inductance of coils connected to the COIL terminals.

a. If the approximate value of inductance is known, select the appropriate measuring frequency from the INDUCTANCE-FREQUENCY chart on the front panel. Set the frequency controls to the designated frequency.

b. Using the XQ controls, adjust the MULTIPLY Q BY meter to read 1.0 (use a higher multiplying factor for coils of $Q > 250$).

c. Resonate the coil by adjusting the resonating capacitor control for maximum deflection of the CIRCUIT Q meter. Vernier capacitor must be at O.

If the inductance cannot be estimated, resonate the coil at any frequency, then move the oscillator frequency to the nearest frequency specified on the chart, changing the resonating capacitor accordingly.

d. Read the *effective** inductance of the coil on the L scale of the resonating capacitor dial. The value shown on this scale must be multiplied by an appropriate factor, depending on the frequency used and the corresponding range of inductance.

*Effective inductance is defined in the Appendix.

Occasionally it may be necessary to measure inductance at frequencies other than those specified by the chart. In such instances, after resonating the measuring circuit, the effective inductance can be calculated with the equation,

$$L_s = 1/\omega^2 C \quad (3.2)$$

where $\omega = 2\pi$ times the frequency in cycles-per-second

and C = capacitance in farads, as read on the dials of the Internal Resonating Capacitor

Corrections for true inductance are given in the Appendix.

F. LOW FREQUENCY MEASUREMENTS.

The Q Meter Type 260-A may be used at frequencies below 50 KC by connecting the output of an external oscillator to the measuring circuit. A receptacle (shown in Figure VI-1) is provided for this purpose at the rear of the injection resistor housing. The external oscillator must be capable of delivering one ampere to a load of approximately 0.3 ohms. To meet this requirement, most oscillators will have to work through a matching transformer. The BRC Coupling Unit Type 564-A will match an impedance of about 500 ohms to the injection circuit from 50 KC to about 1 KC. Under these conditions the oscillator output level should be approximately 22 volts at the transformer primary.

The secondary of the Coupling Unit Type 564-A terminates in a UG-88/U connector. The injection circuit receptacle which fits this connector is accessible through a door in the rear panel. Remove the internal oscillator connector and replace it with the connector from the Coupling Unit.

CAUTION: Before this connection is made, make sure the output control on the external oscillator is turned to zero.

Measurements at frequencies below 50 KC will usually require a substantial increase in measuring-circuit capacitance. External standard capacitors, other than polarized or high-loss types, may be connected directly to the CAP terminals for this purpose. The total circuit capacitance is then the sum of internal and external capacitances.

As the measuring frequency decreases, the importance of short leads is reduced. It is good practice, however, to keep the external capacitor as close as possible to the CAP terminals of the Q Meter.

Measurement of Q, X, R, and L or C is made in the normal manner. If high-Q inductors are measured at low frequencies, and either effective or true Q and L is needed, corrections should be made for the input conductance of the Q voltmeter and the distributed capacitance of the test coil. These corrections are discussed in Section V and the Appendix.

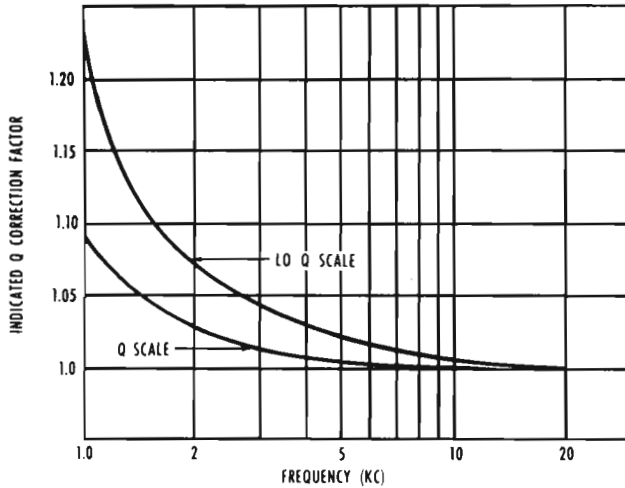

Figure III-4 Low Frequency Q Voltmeter Correction

The Q voltmeter circuit is by-passed for optimum performance for frequencies between 50 KC and 50 MC. The frequency response of the voltmeter is therefore not flat to low audio frequencies. A correction curve for the Q voltmeter is given in Figure III-4.

SECTION IV PRINCIPLE OF OPERATION

A. GENERAL.

The measuring principle of the Q Meter Type 260-A is based on a familiar characteristic of series resonant circuits, namely, that the magnitude of voltage appearing across either reactor is equal to the voltage induced into the circuit multiplied by the *circuit* Q. In the Q Meter Type 260-A the voltage is induced across a 0.02 ohms resistor in series with the circuit. Circuit Q is defined as the Q of the internal measuring circuit of the Q Meter, in conjunction with the component under test. In most practical cases this is essentially equal to the Q of the component alone.

B. Q METER THEORY.

When the circuit of Figure IV-1 is resonant, by defi-

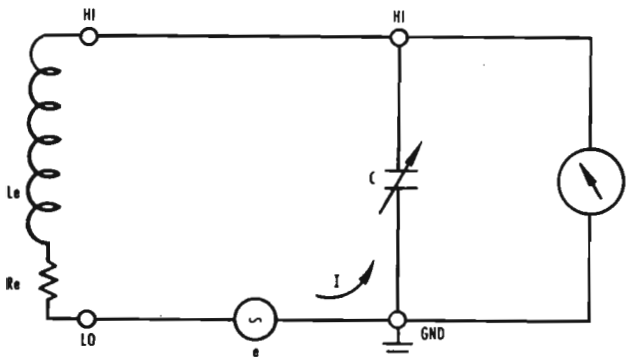

Figure IV-1 Basic Measuring Circuit

inition $\omega L_e = 1/\omega C$ and the series resistance of the circuit is R_e , we can write for the current, I,

$$I = e/R_e.$$

We can also write,

$$E = I\omega L_e = I/\omega C.$$

Combining these expressions and solving for E/e,

$$E/e = \omega L_e/R_e = 1/\omega C R_e$$

or,

$$E/e = Q_e.$$

This equation is sensibly correct if the *circuit* $Q \geq 10$.

C. RESIDUAL CIRCUIT PARAMETERS.

The reduction of the ideal circuit configuration of Figure IV-1 to a physical and practical structure inherently introduces residual parameters which do not exist in the ideal circuit.

These parameters have been minimized in the design of the 260-A using means developed over many

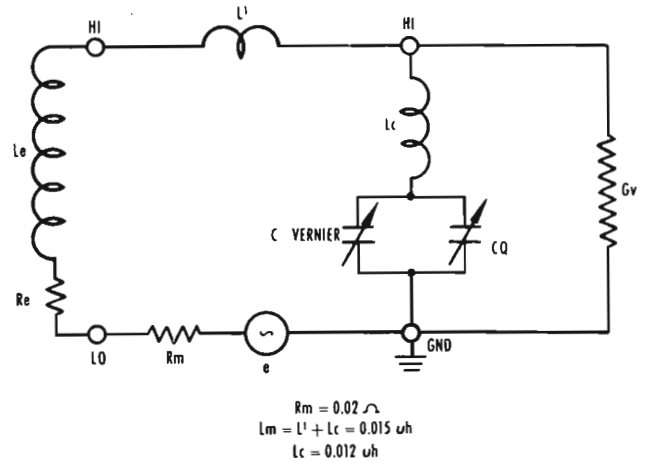

Figure IV-2 Equivalent Measuring circuit (Approximate)

years of experience. As a result, practically all measurements can be made without corrections for these residuals, except where extreme accuracy is required.

The equivalent circuit of the Q Meter measuring circuit, to a first approximation, is shown in Figure IV-2. Average values of residual parameters are also given. In general, these values are satisfactory for most purposes. Accurate measurements, however, require that these quantities be determined for each individual Q Meter, and references for these measurements are included in the bibliography.

SECTION V SOURCES OF ERROR

A. INSERTION RESISTANCE.

While, for many measurements, the residual resistance of the Q Meter measuring circuit, shown in Figure IV-2, is sufficiently small to be considered negligible, under certain conditions it can contribute an error to the measurement of Q.

The degree of influence of this residual resistance on a measurement depends on the magnitude of the impedance of the unknown component with respect to the residual impedance. For instance, the 20 milliohms of insertion resistance may be safely neglected in comparison with an effective series coil resistance of 10 ohms but assumes importance when compared with an effective coil resistance of 0.1 ohms. Consider the following example:

$$\begin{aligned} f &= 1.0 \text{ MC} \\ C &= 65 \mu\mu\text{f} \\ \text{and } R_s &= 10 \text{ ohms} \end{aligned}$$

Then the *effective* Q of the coil equals,

$$Q_e = 1/\omega CR_s = 245,$$

while the *indicated* Q equals,

$$\begin{aligned} Q_i &= 1/\omega C (R_s + 0.02) \\ &= 244.5, \end{aligned}$$

an error of only 0.2 percent.

However, when the coil resistance is, say 0.1 ohms, and we are interested in learning the *effective* Q of the coil, we must correct for the insertion resistance, for example:

$$\begin{aligned} f &= 40 \text{ MC} \\ C &= 135 \mu\mu\text{f} \\ \text{and } R_s &= 0.1 \text{ ohms} \end{aligned}$$

Then the *effective* Q of the coil equals,

$$Q_e = 1/\omega CR_s = 295$$

but the *indicated* Q equals,

$$Q_i = 1/\omega C (R_s + 0.02) = 245$$

The equations which follow correct for insertion resistance errors:

Effective coil resistance,

$$R_s = (1/\omega C Q_i) - (2 \times 10^{-2}) \quad (5.1)$$

$$\text{Effective } Q, Q_e = \frac{Q_i}{1 - \frac{\omega C Q_i}{50}} \quad (5.2)$$

where $\omega = 2\pi$ times the frequency in cycles-per-second

C = capacitance in farads, as read on the dials of the Internal Resonating Capacitor

and Q_i = indicated Q

Error due to the insertion resistor will be 5 percent, or less, for values of indicated Q equal to, or less than, those values shown in Figure V-1 for attendant values of frequency and capacitance. When the effective Q of a coil is needed to an accuracy of better than 5 percent of the indicated Q, corrections should be made for all indicated Q values which exceed those shown in Figure V-1 (for corresponding setting of f and C).

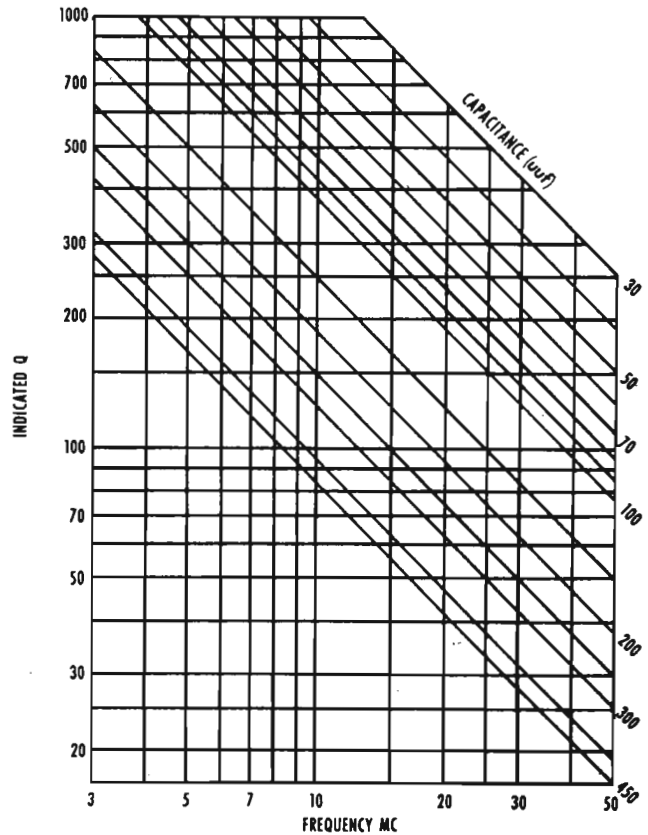

Figure V-1 Circuit Q Correction Guide for Insertion Resistor Error. Indicated Q's for given values of resonating capacitance and frequency below those shown on the chart are less than 5% in error.

B. RESIDUAL INDUCTANCE.

The residual inductance in series with the COIL terminals of the Q Meter is included as part of the measured inductance of unknown coils (when using Direct Connection—see Figure III-1). When accurate values of effective inductance are required, correction for the residual inductance is necessary for coils of less than 0.5 microhenries (approximately). The correction is simply,

effective L,

$$L_e = L_{\text{meas.}} - L_m$$

where the residual inductance, L_m , is approximately 0.015 μh .

The effect of distributed capacitance on measured values of Q and inductance is discussed in the Appendix.

C. Q VOLTMETER CONDUCTANCE.

Another internal parameter which causes the *indicated* Q to deviate from *effective* Q, at both very low and very high frequencies, is the input conductance of the Q voltmeter circuit. At very low frequencies this conductance consists of a 100 megohm grid leak resistor in parallel with the internal losses of the vacuum tube. At very high frequencies the transit time loss in the voltmeter tube shunts the resonating capacitor and introduces a shunt resistance across the measuring circuit.

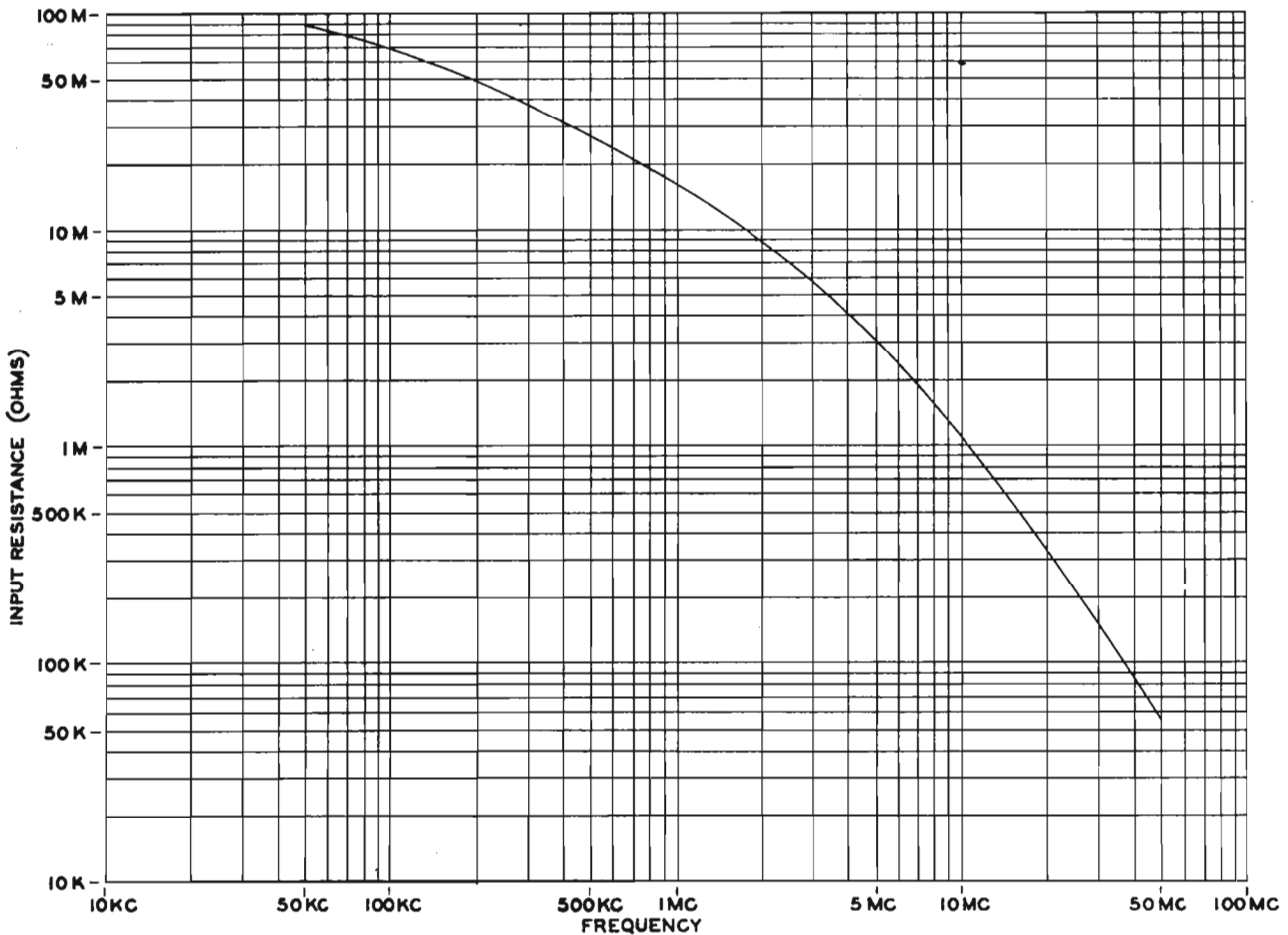

Figure V-2 Typical curve of Q voltmeter input resistance vs. frequency

Q values, altered by this circuit loss, may be corrected with the equation,

effective Q,

$$Q_e = \frac{Q_i}{1 - \frac{Q_i G_v}{\omega C}} \quad (5.4)$$

where Q_i = indicated Q

and G_v = input conductance of the Q voltmeter.

Corrections for Q's of less than 50 or 60 are seldom, if ever, necessary. G_v should therefore be measured with the CIRCUIT Q meter lever key in its normal (Q) position. Corrections based on values of G_v measured in this way will then apply only to the normal Q scale.

A typical curve of Q voltmeter input resistance vs. frequency is shown in Figure V-2.

D. CORRELATION OF Q.

The Q Meter Type 260-A contains improvements developed through years of experience in Q Meter design. The residual internal parameters of the measuring circuit have been reduced over those of the preceding BRC Q Meter, Type 160-A.

The signal insertion resistance, for example, has

been reduced 50 percent (from forty to twenty milliohms) and the inductance of this resistor has been made negligible. Circuit improvements have also lowered the input conductance of the Q voltmeter at the lower frequencies.

Thus the Q's of inductors measured directly at the COIL terminals of the 260-A depart very little from their effective values. When comparison measurements are made, therefore, using the Type 260-A and 160-A Q Meters, a difference of indicated Q must be expected.

The difference is most apparent at low and high frequencies. Most measurements made from 500 KC to about 5 MC will have good agreement.

SECTION VI MAINTENANCE

A. GENERAL.

The Q Meter Type 260-A is a precision-built, factory-calibrated instrument, and because the special test and calibration equipment necessary is, in most cases, not readily available, field maintenance must be limited to certain practical operations if the accuracy of the instrument is to be retained.

It is the policy of the Boonton Radio Corporation to make available to its customers such service as is needed to maintain its products within specifications, as advertised, at a reasonable cost. If the accuracies of the Q Meter Type 260-A appear to be impaired, it is recommended that the instrument be returned to the factory. Maintenance operations beyond the scope of this section should be referred to the factory.

Generally, all troubles other than tube replacement and routine circuit repair, can best be handled at our factory. However, experienced engineers and technicians may replace thermocouple assemblies in the event of failure if our instructions are carefully followed.

NOTE: It is recommended that careful measurements be made, using a set of Inductors Type 103-A as soon as the Q Meter is placed in operation. These data should be filed for each individual Q Meter and reference made to these measurements in the event maintenance work becomes necessary. At least one measurement should be made near each end of the frequency band of each inductor. Similar measurements should be made using Q-Standards Type 513-A and 518-A in the event that recalibration of the instrument is ever necessary.

B. REMOVING THE INSTRUMENT FROM ITS CABINET.

Although removal of the instrument from its cabi-

net is a simple operation, it must be done with care.

Remove the screws from around the edge of the top and front panels and the 3 screws from the bottom of the instrument. The entire front panel and top may then be lifted out of the cabinet and carefully placed on end with the oscillator compartment nearest the bench. The cable and plug connecting the voltage stabilizer (not present in the Type 260-AP) to the power supply may be removed from the power supply chassis if further separation of the instrument and cabinet is required.

If repair work on the Q Meter is interrupted, the instrument should be returned to its cabinet temporarily to prevent dust from settling between the plates of the resonating capacitor.

C. REPLACEMENT OF TUBES.

1. GENERAL.

Four of the five electron tubes in the Q Meter Type 260-A may be replaced with commercial grade tubes. The Q voltmeter triode (V-301, type BRC 535-A), however, is specially manufactured and if replacement of this tube is necessary it must be obtained from the Boonton Radio Corporation. Any substitution may drastically impair operation of the Q Meter.

When any of the tubes, except the voltage regulators, V-402 (type OB2) and V-403 (type OA2) and rectifier V-401 (type 6X4), are replaced, recalibration

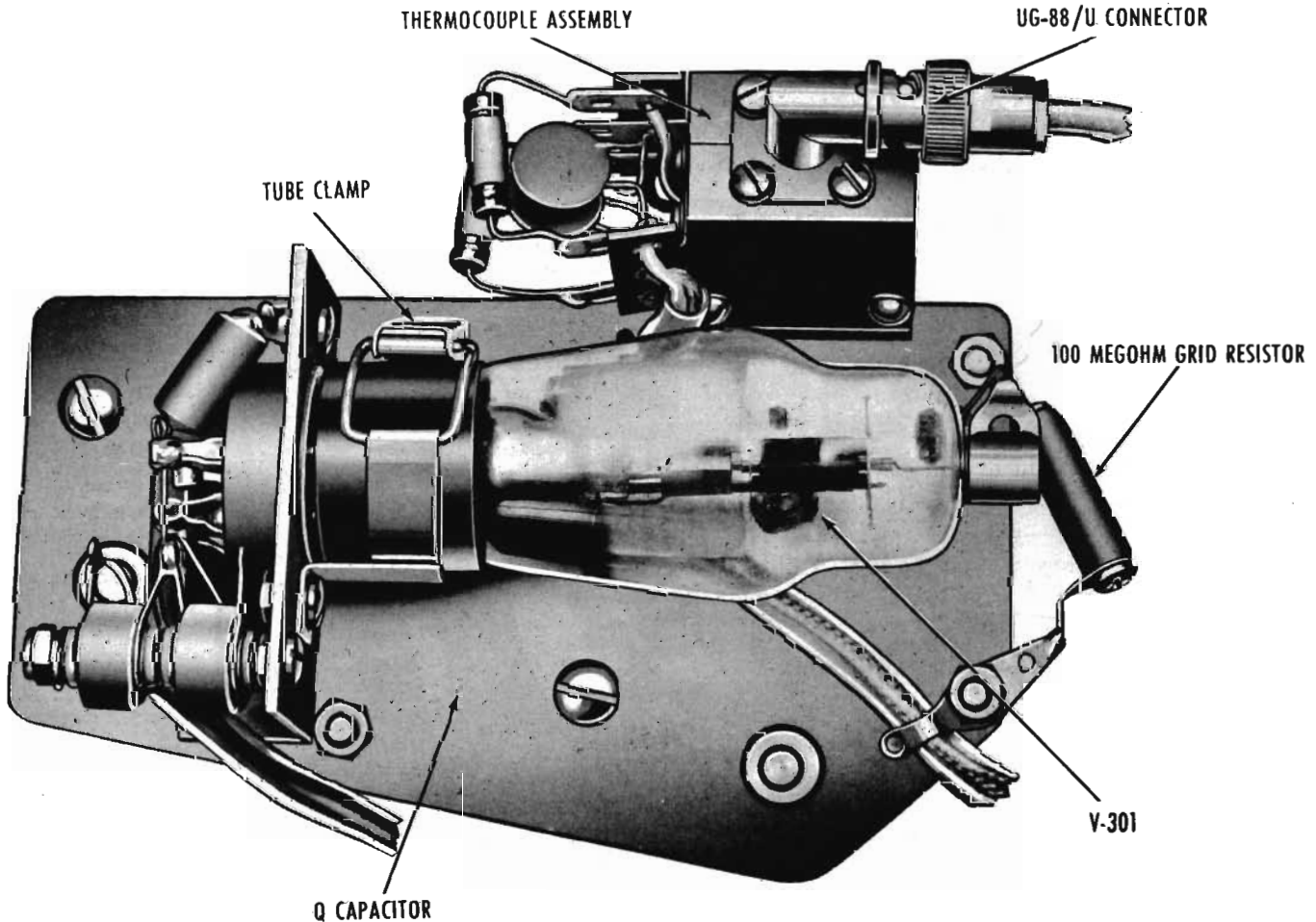

Figure VI-1 Resonating capacitor, Q voltmeter tube, and thermocouple assembly

is required to retain the full accuracy of the instrument. The procedures are described in this section. All components which require adjustment are shown in Figures VI-2 and VI-3.

2. REPLACEMENT OF THE VOLTMETER TUBE, V-301 (TYPE BRC 535-A).

a. Carefully remove the grid cap and release the clamp at the base of the tube (Figure VI-1).

b. Withdraw the tube from its socket, insert the new voltmeter tube and lock the clamp. Make certain no dust or grease is on the glass envelope and then replace the grid cap.

During the withdrawal and replacement of the tube, relieve any strain from the resonating capacitor frame by supporting the tube socket subchassis with one hand.

c. Check the voltmeter calibration as described in Section VI-E-1.

3. REPLACEMENT OF THE OSCILLATOR TUBE, V-101 (TYPE 5763).

a. Remove the nine screws which hold the cover in place on the oscillator compartment (Figure VI-2). It is suggested that the frequency control be turned clockwise so that the main variable oscillator capacitor is fully meshed to avoid accidental bending of the plates.

b. To remove the oscillator tube, first depress the shield and turn it slightly to the left, then lift off. Remove the faulty tube and insert the new tube. Properly align the pins of the new tube before applying pressure to the glass envelope. Replace the tube shield.

c. After replacing the compartment cover, check the oscillator calibration according to Section VI-E-2.

4. REPLACEMENT OF THE RECTIFIER, V-401 (TYPE 6X4) AND VOLTAGE REGULATORS, V-402 (TYPE OB2) AND V-403 (TYPE OA2).

a. These tubes are located on the power supply chassis (Figure VI-3) and are easily removed for replacement. No adjustments are required when any of these tubes are replaced.

D. REPLACEMENT OF THE THERMOCOUPLE ASSEMBLY.

1. GENERAL.

Burn-out of the thermocouple may occur if it is subjected to a severe overload. For the prevention of thermocouple burn-out see Section III-C. If a burn-out does occur, a new thermocouple assembly must be ordered from our factory. This assembly includes a 0.02 ohm insertion resistor, a thermocouple, calibration resistors for the MULTIPLY Q BY meter, and filter capacitors.

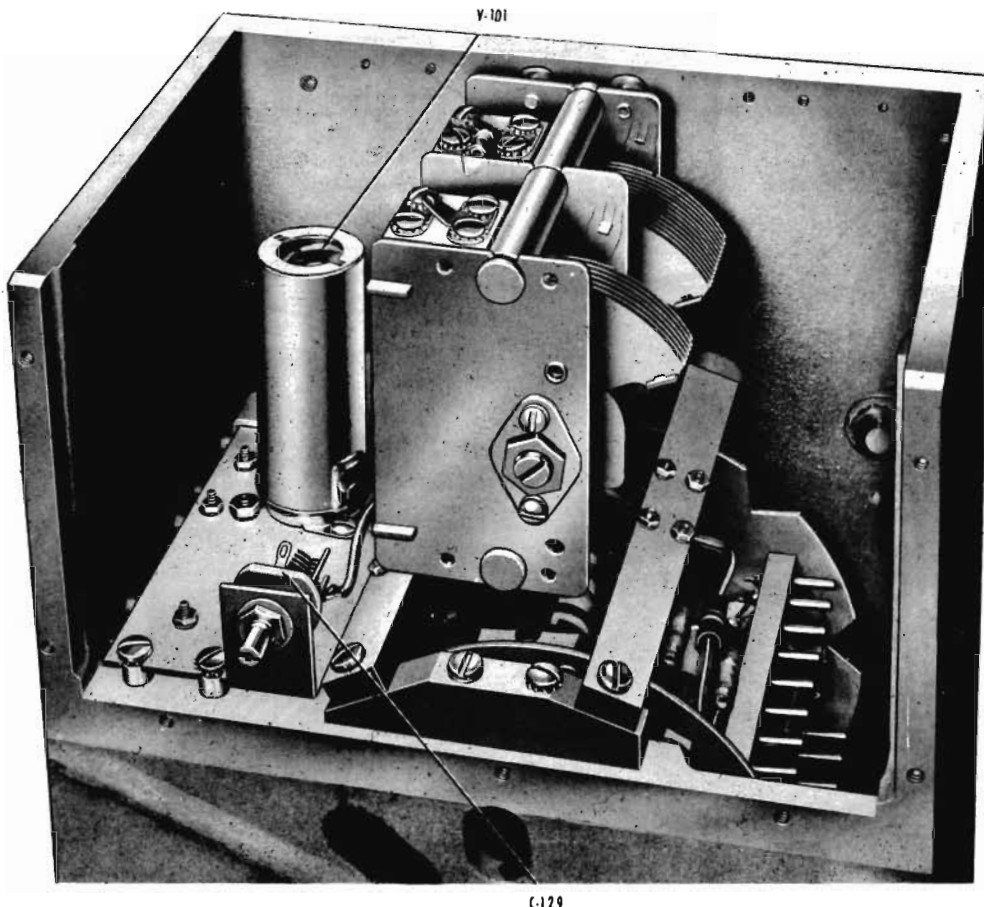

Figure VI-2 Oscillator compartment showing tube and calibration adjustment capacitor

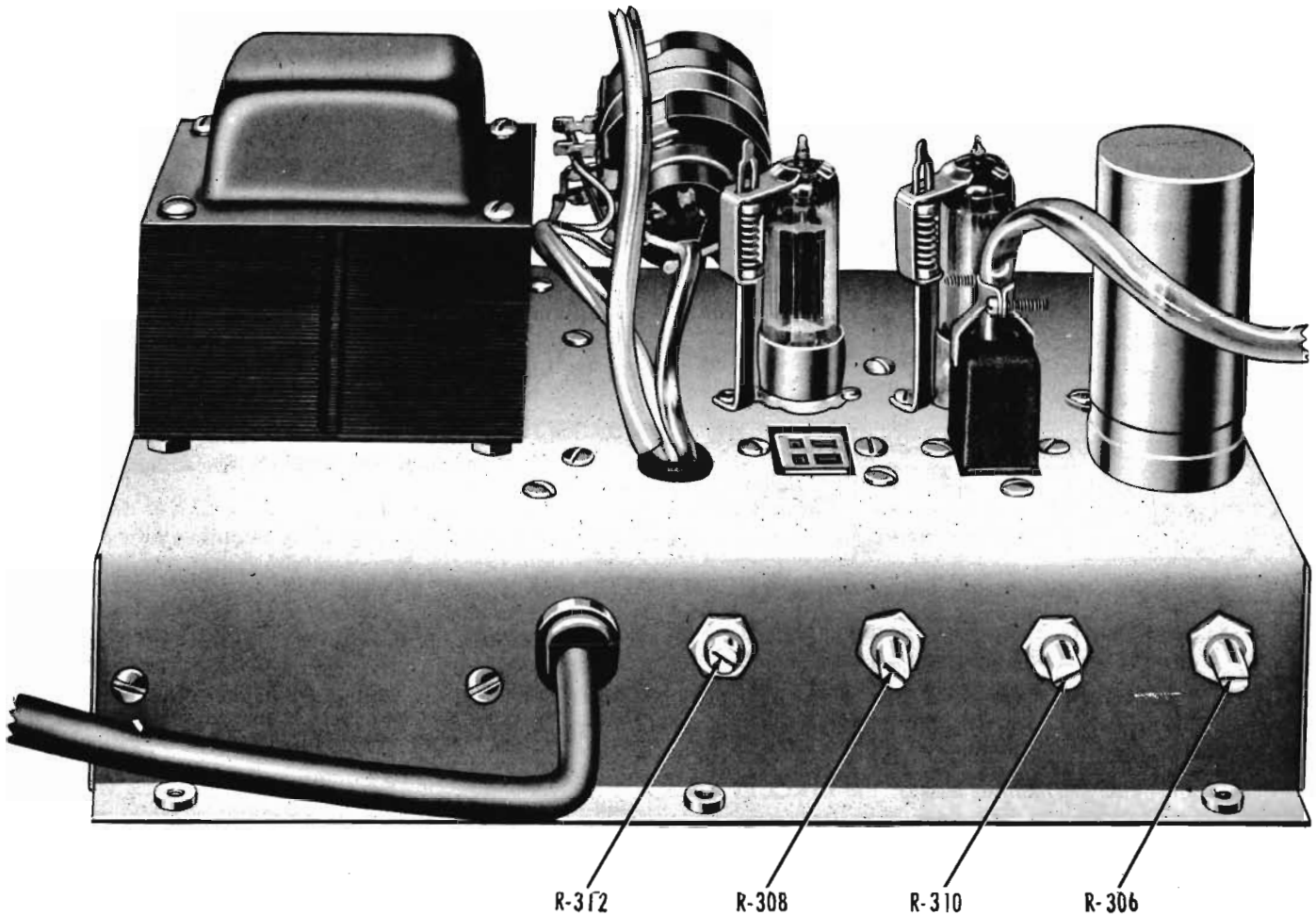

Figure VI-3 Power Supply chassis showing Q voltmeter calibration adjustments

NOTE: Because the value of the calibration resistors are partially determined by the internal resistance of the MULTIPLY Q BY meter, it is necessary that our factory know the type and serial number of the inoperative Q Meter. This information must be furnished when ordering a new thermocouple assembly.

2. REPLACEMENT OF THE THERMOCOUPLE ASSEMBLY.

a. Remove the UG-88/U plug from its receptacle at the rear of the thermocouple assembly (Figure VI-1).

b. Unscrew and remove the LO binding post finger nut to reduce the heat required to unsolder the strap. Then carefully unsolder the strap that emerges from

the assembly housing and connects to the bottom of the LO post. See Figure VI-4.

c. Remove the terminal lugs from the MULTIPLY Q BY meter, unsolder the ground lead, and unclamp the cable from the front panel and resonating capacitor frame.

d. Remove the four mounting screws for the thermocouple assembly located on top of the instrument just in back of the LO binding post. Carefully extract the assembly from the Q Meter.

e. Install the new unit and connect the attached cable to the MULTIPLY Q BY meter terminals. Observe the indicated polarity. Reclamp the cable to the resonating capacitor frame and front panel.

f. Trim the connecting strap to a length that will permit it to reach the LO post with a small amount of slack to allow for motion of the binding post. Carefully solder this strap to the bottom of the LO binding post. Replace the top nut on the binding post.

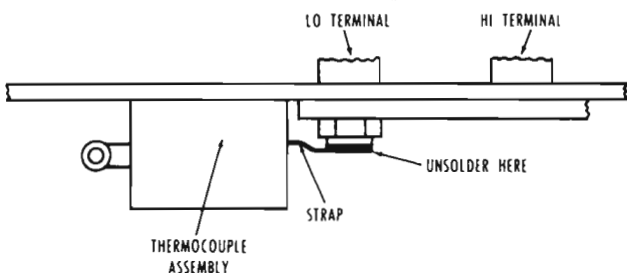

Figure VI-4 Location of injection circuit connecting strap

E. ADJUSTMENT AND CALIBRATION.

1. VOLTMETER CALIBRATION.

When the voltmeter tube or other voltmeter circuit components are replaced, all voltmeter scales should be

recalibrated for maximum accuracy. The following equipment is required:

A signal source of 20 KC to 100 KC with an adjustable output up to 5 volts and less than 1 percent distortion. The d-c resistance of the source should not exceed one megohm. If the output is capacitively coupled to its terminals, connect a terminating resistor across the CAP terminals.

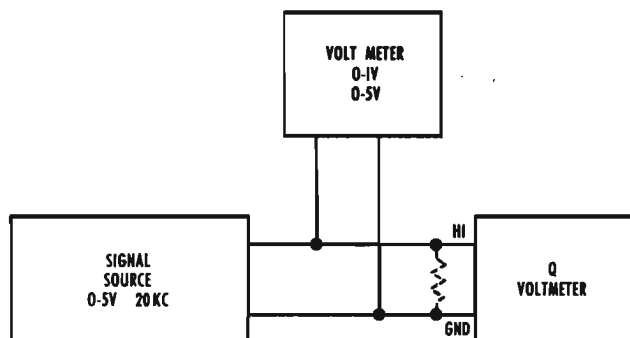

Figure VI-5 Q voltmeter calibration circuit

An a-c voltmeter, 0-1 and 0-5 volts, with an accuracy of 2 percent at the signal frequency.

Connections are shown in Figure VI-5. The procedure is as follows:

PRELIMINARY.

a. Adjust the mechanical zero of the CIRCUIT Q meter before turning on the power.

b. Because the output of the internal oscillator is not used during the voltmeter calibration, the XQ control need only be turned enough to actuate the power switch. Turn on the power and allow a warm up period of at least 15 minutes.

ZERO SET.

c. Strap the HI and GND terminals of the measuring circuit together.

d. To provide maximum control for the Q ZERO potentiometer, set the Q ZERO control to its mid-position and approximately zero the CIRCUIT Q meter with R-312 (Figure VI-3).

e. Carefully zero the CIRCUIT Q meter using the Q ZERO control and both the Q and LOW Q positions of the lever key as described in Section III-E-1-e.

f. Remove the shorting strap and set the resonating capacitor at minimum capacitance. Connect the calibrating equipment as shown in Figure VI-5.

Q VOLTMETER.

g. Apply successively 5, 4, 3, 2, and 1 volt, adjusting R-310 (Figure VI-3) to obtain the best overall accuracy of Q readings which should be 250, 200, 150, 100, and 50, respectively.

LOW Q VOLTMETER.

b. With the lever key depressed to the LOW Q position, successively apply 1.2, 1.0, 0.8, 0.6, 0.4, and 0.2 volts, adjusting R-308 (Figure VI-3) to obtain the best overall accuracy of LOW Q readings which should be 60, 50, 40, 30, 20, and 10, respectively.

ΔQ VOLTMETER.

i. Apply 3.0 volts to the Q voltmeter.

j. Raise the lever key to the ΔQ position and adjust the COARSE and FINE ΔQ BALANCE controls until the meter needle reads 50 on the ΔQ (red) scale. Note: This is *not* the usual operating adjustment: ordinarily the meter needle is adjusted for a ΔQ of zero.

k. With the lever key still in the ΔQ position, apply successively 3.2, 3.4, 3.6, 3.8, and 4.0 volts, adjusting R-306 (Figure VI-3) to obtain the best overall accuracy of ΔQ readings which should be 50, 40, 30, 20, 10, and 0, respectively.

2. OSCILLATOR CALIBRATION (C-129 ADJUSTMENT).

When the oscillator tube is changed, it is necessary to check the frequency calibration. Because a tube change affects only the capacitance of the circuit, recalibration is only necessary on one frequency band.

A 10 MC crystal calibrator is recommended for this operation. However, standard broadcast stations may be satisfactorily used in lieu of the crystal calibrator.

To calibrate the oscillator, proceed as follows:

a. Turn on the Q Meter and allow at least 15 minutes warm-up time.

b. Connect the r-f input terminals of the crystal calibrator to the LO and GND terminals of the measuring circuit.

c. Adjust the calibrator to 10 MC.

d. Switch the frequency range to the 4.2-10 MC range. Set the MEGACYCLE dial to exactly 10 MC.

e. Adjust the XQ controls for a reading of 1.0 on the MULTIPLY Q BY meter.

f. Carefully adjust C-129 (Figure VI-2) until a zero beat is heard in the calibrator headset.

Standard broadcast stations in the neighborhood of 700 KC or 1500 KC may also be used, in conjunction with a radio receiver, to calibrate the oscillator. The upper ends of either the 300-700 KC or 700-1700 KC ranges may be used to zero beat the Q Meter oscillator with the station carrier.

F. POWER SUPPLY CHECK.

A check of the power supply should be made if the Q Meter is operating erratically and no other fault is apparent. All the important voltages may be checked between the points listed below and ground. Erratic operation of either regulator tube can often be determined by visual examination. Fluctuations of the discharge glow within the tube is usually evidence of a poor regulator tube.

BOONTON RADIO CORPORATION

Test	Voltage	Pin	Socket	Tolerance
Unregulated d-c voltage	Variable with range (Approx. 315 VDC on range 1 to 285 VDC on range 8)	1	J-401	
*Oscillator screen voltage	Variable with XQ controls	6	J-401	
Regulated d-c for Q voltmeter	258 VDC	1	V-402	±2 volts
Regulated d-c for Q voltmeter	150 VDC	1	V-403	±1 volt
Q voltmeter heater	2.25 VAC	6	V-301	±1%
Oscillator heater	6.0 VAC	3	J-401	±1%

Instrument required: DC/AC Multitester, ±2%, 1,000 ohms/volt or more.

G. TROUBLE SHOOTING.

1. GENERAL.

The electrical simplicity of the circuitry of the Q Meter Type 260-A makes trouble shooting a straightforward operation. Observation of the two meters and a few simple tests will sometimes indicate the trouble before the instrument is removed from its cabinet. If further investigation is necessary, reference to the schematic diagram, combined with continuity and voltage analysis with a multitester will usually reveal the source of trouble.

A few troubles which may be encountered are given below in terms of external symptoms, together with the probable cause(s). It should be remembered, however, that in addition to the probable cause(s) given in this table, any of these troubles may be due to defective components, such as resistors, capacitors, transformers, etc.

Symptom	Possible Cause(s)
No meter indications of any kind.	Faulty rectifier tube.
Downward deflection of CIRCUIT Q meter. No Q ZERO adjustment possible. Normal MULTIPLY Q BY readings.	Faulty Q Voltmeter tube (V301).
Erratic Q readings.	Faulty voltage regulator tubes (V402, V403).
No MULTIPLY Q BY readings. CIRCUIT Q meter reacts to the touch of a finger on the HI terminals.	Faulty oscillator tube (V101) or burned-out thermocouple unit. The trouble may be isolated by listening for oscillations with a radio receiver.
Impossible to set ΔQ meter to zero.	Check R304, R306 and R307.
No CIRCUIT Q meter reading on LO Q.	Check S301, R308.

*Do not increase this voltage without observing the reading on the MULTIPLY Q BY meter. THIS READING SHOULD NEVER EXCEED X 1.0.

Symptom	Possible Cause(s)
CIRCUIT Q meter reads near mid-scale, no zero adjust.	Faulty bucking voltage bleeder resistor. Check R305, R307, R311 and R312.
Irregular or erratic readings on Q, ΔQ, LO Q scales.	Dirty contacts or loose wipers on potentiometers or key switch.

APPENDIX

A. NOMENCLATURE.

In the following nomenclature for parallel and series measurements, the subscript 1 (as in C_1 , Q_1) will denote values measured with only the work coil connected to the measuring circuit. The subscript 2 (as in C_2 , Q_2) will refer to values measured after the unknown is added to the circuit.

For other measurements the subscript 1 will refer to the first reading while the second reading will be identified by the subscript 2.

Subscripts "p" and "s" will denote parallel and series parameters, respectively.

The units are defined as follows:

C = capacitance of the Q capacitor as indicated on the main and vernier dials	(farads)
Q = indicated Q observed on the meter	
ΔQ = change in Q; $\Delta Q = Q_1 - Q_2$	
f = oscillator frequency	(cys/sec)
$\omega = 2\pi f$	
L = inductance	(henries)
R = resistance	(ohms)
L_m = residual inductance referred to the COIL terminals	(henries)
L_c = residual inductance referred to the capacitor (CAP) terminals	(henries)
G_v = input conductance of the Q voltmeter	(mhos)
C_d = distributed capacitance of an inductor	(farads)
f_o = self-resonant frequency of an inductor	(cys/sec)

B. DISTRIBUTED CAPACITANCE.

1. GENERAL.

The presence of distributed capacitance in a coil modifies the effective Q and inductance of the coil. At the frequency at which the distributed capacitance and the inductance of the coil are resonant, the circuit exhibits a purely resistive impedance. Typical variations of the effective Q and L under these conditions with frequency are shown in Figure A. The true Q and in-

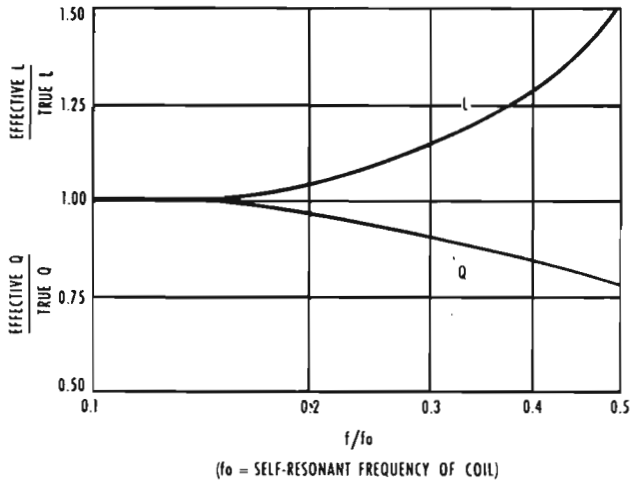

Figure A Typical variation of effective Q and inductance with frequency

ductance may be determined, however, if the value of distributed capacitance is known. Figure B is a chart which gives ratios of effective inductance to true inductance and true Q to effective Q for various values of distributed capacitance and Q capacitance.

The chart also illustrates that the effective inductance and Q will closely approximate true values if the distributed capacitance is not excessive and the Q capacitance which tunes the coil is large.

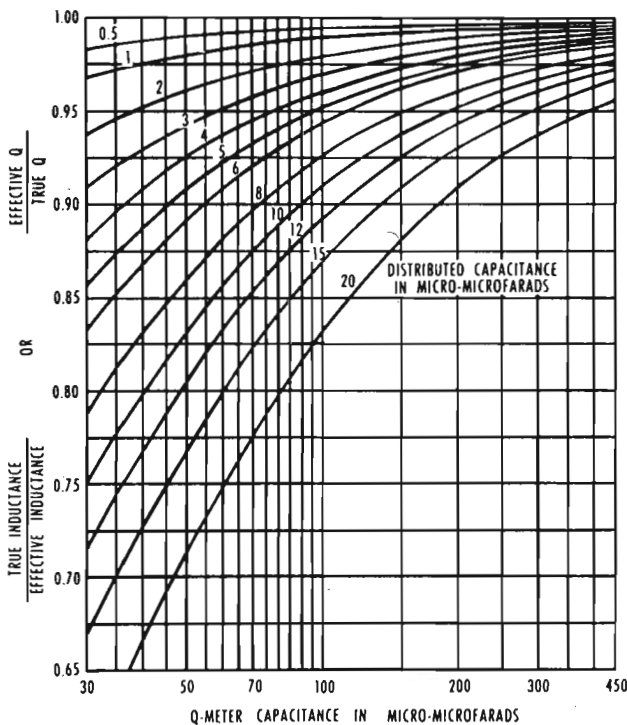

Figure B Correction chart for distributed capacitance

2. MEASURING C_d (PREFERRED METHOD)

The impedance of a coil at its self-resonant frequency is resistive and usually high. This characteristic may be utilized for the measurement of distributed

capacitance. Proceed as follows:

a. Set the resonating capacitor to about 400 $\mu\mu\text{f}$. Call this value C_1 .

b. Connect the coil to be measured to the COIL terminals and resonate the measuring circuit by adjusting the oscillator frequency. When resonance is established, note frequency f_1 .

Now find the self-resonant frequency of the coil, as follows:

c. Reset the oscillator frequency to approximately ten times f_1 and replace the test coil with a work coil capable of resonating in the measuring circuit at this higher frequency.

d. Adjust the resonating capacitor for circuit resonance.

e. Connect the test coil to the CAP terminals and restore resonance by readjusting the resonating capacitor.

f. If the capacitance has to be increased, increase the oscillator frequency until alternately connecting and disconnecting the test coil to the CAP terminals changes the indicated Q but does not affect the tuning. Call this frequency the self-resonant frequency, f_0 . Likewise, if the capacitance must be decreased, the frequency should be decreased until the self-resonant frequency of the coil obtains. Unless the required change of capacitance is very small, the frequency should be changed at first in reasonably large steps, for example, 20 to 30 percent.

The distributed capacitance may be found from,

$$C_d = \frac{C_1}{\left(\frac{f_0}{f_1}\right)^2 - 1} \quad (\text{farads}) \quad (1)$$

If $f_0 \gg f_1$, this expression reduces to

$$C_d = \left(\frac{f_1}{f_0}\right)^2 C_1 \quad (\text{farads})$$

3. MEASURING C_d (APPROXIMATE METHOD— $C_d \geq 10 \mu\mu\text{f}$).

The distributed capacitance of coils with large values of C_d may be approximated with a simple measuring procedure.

a. Set the resonating capacitor to about 50 $\mu\mu\text{f}$. Call this value C_1 .

b. Connect the test coil to the COIL terminals and resonate the measuring circuit by adjusting the oscillator frequency. Note this frequency as f_1 .

c. Reset the oscillator to a lower frequency, f_2 , equal to f_1/n . Restore resonance by increasing the resonating capacitance. Let this new value of capacitance be C_2 . The distributed capacitance is then,

$$C_d = \frac{(C_2 - n^2 C_1)}{n^2 - 1} \quad (\text{farads}) \quad (2)$$

If f_2 is made exactly one half of f_1 , then

$$C_d = \frac{C_2 - 4C_1}{3} \quad (\text{farads})$$

An average of several measurements using different values of C_1 will improve the results of this measurement. The best accuracy to be expected with this method, however, is in the order of $\pm 2 \mu\mu\text{f}$.

4. CORRECTION FOR Q.

The effective Q of a coil with distributed capacitance is less than the true Q by a factor that depends on the value of the distributed capacitance and the measuring circuit resonating capacitance. It can be shown that,

$$\text{true } Q = Q_e \left(\frac{C + C_d}{C} \right) \quad (3)$$

Where Q_e = effective Q of the coil
and C = measuring-circuit resonating capacitance

The effective Q can usually be considered the indicated Q. Exceptions are discussed in Section V.

A graphical solution for the above equation is given in Figure B.

5. CORRECTION FOR INDUCTANCE (MEASURED AT COIL TERMINALS).

The Q Meter Type 260-A measures the effective inductance of coils, except where the measured inductance is in the vicinity of 0.5 microhenries or less. In these cases, the internal inductance of the measuring circuit, L_m , must be subtracted from the measured value (see Section V).

The effective inductance of a coil with distributed capacitance is somewhat greater than its true inductance. Ratios of true inductance to effective inductance can be found from Figure B for various values of distributed and resonating capacitance. The true inductance can also be calculated from,

$$\text{true inductance} = L_e \left(\frac{C}{C + C_d} \right) \quad (\text{henries}) \quad (4)$$

where L_e = effective inductance of the coil
and C = measuring-circuit resonating capacitance

While the true inductance may be calculated from the above equation or obtained graphically from Figure B, a simpler method can be used which utilizes both scales on the resonating capacitor dial. This dial contains an inductance scale based, at selected frequencies, on the equation, $L = 1/\omega^2 C$ where C can be read directly above the measured inductance on the capacitance scale. This is the effective inductance of the coil. The true inductance resonates with the sum of the resonating capacitance and the distributed capacitance, thus, true $L = 1/\omega^2(C + C_d)$.

If the distributed capacitance is known, a correction yielding true inductance can be made as follows:

a. If the approximate value of inductance is known, select the appropriate measuring frequency from the

INDUCTANCE-FREQUENCY chart on the panel. Set the frequency controls to the designated frequency.

b. Using the XQ controls, adjust the MULTIPLY Q BY meter to read 1.0 (use a higher multiplying factor for coils of $Q > 250$).

c. Resonate the coil by adjusting the resonating capacitor control for a maximum deflection of the CIRCUIT Q meter.

If the inductance cannot be estimated, resonate the coil at any frequency, then move the oscillator frequency to the nearest frequency specified on the chart, changing the Q capacitor accordingly.

d. Read the effective inductance of the coil on the L scale of the Q capacitor dial. The value shown on this scale must be multiplied by an appropriate factor, depending on the frequency used and the corresponding range of inductance.

e. With the measuring circuit at resonance, note the value of Q capacitance and add to this the distributed capacitance of the coil. Advance the dial then, to read the sum of C plus C_d . Although the measuring circuit is detuned by this procedure, the true inductance of the coil can now be read directly on the inductance scale.

This correction is shown in Figures C-1 and C-2 for a coil whose effective inductance was 49 microhenries and distributed capacitance measured 7 micro-microfarads. The true inductance of the coil was found to be 45 microhenries.

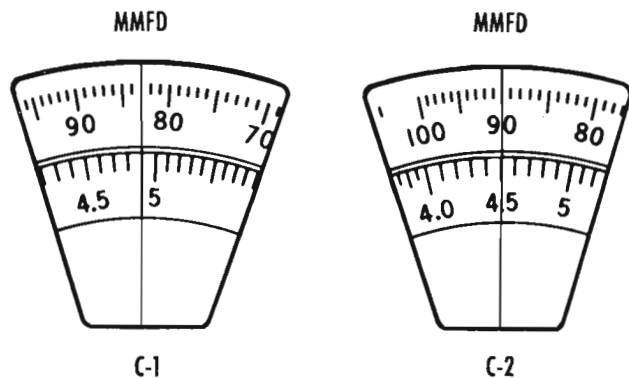

Figure C Using the LC dial to determine true inductance

C. PARALLEL MEASUREMENTS.

1. GENERAL.

High impedance components, such as high value resistors, certain inductors, and small capacitors, are measured by connecting them across the CAP terminals. This connection is shown in Figure III-2. Before the unknown is connected, however, the measuring circuit must be resonated, using an Inductor Type 103-A or other stable coil, to establish reference values of Q and C. Then, when the component under test is connected to the circuit and the capacitor is readjusted for resonance, the altered values of Q and C can be combined

with the reference values in equations which yield the parameters of the unknown specimen.

2. LARGE RESISTORS.

When the measuring circuit is at resonance (using a work coil), a resistor placed in parallel with the resonating capacitor will lower the indicated Q. The smaller this resistance, the greater the reduction of Q. A reasonable range of resistance may be measured with the parallel method, providing that ΔQ is not less than 5, nor the indicated Q reduced below 10.

The limits of measurable resistance are dependent on frequency and both maximum and minimum limits decrease as the frequency increases. Figure D shows approximate limits for both parallel and series measurements. These limits are based on a maximum Q₁ of 250, although higher Q's are feasible for measurements outside the ranges shown. The lower limits for parallel measurements may also be extended by using external standard capacitors connected to the CAP terminals.

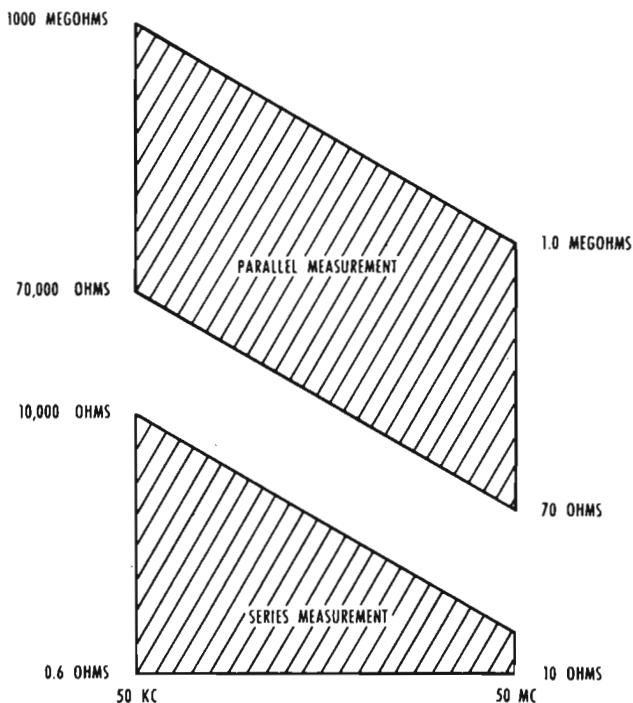

Figure D Ranges of measurable resistance

The following procedure may be used for the measurement of large resistors:

a. Set the oscillator controls to the desired measuring frequency.

b. Connect a suitable work coil to the COIL terminals and adjust the resonating capacitor for resonance mentally noting this value of Q₁. Set the MULTIPLY Q BY meter to the appropriate multiplying factor; preferably X1.

The work coil should be selected so that larger resistors are measured with small values of resonating

capacitance and smaller resistors are measured with large values of tuning capacitance.

c. Set the ΔQ coarse control (outer knob) and its attached dial to the approximate value of Q₁. Lift the lever key to the ΔQ position and adjust the fine ΔQ BALANCE control (center knob) for a meter reading of zero on the ΔQ scale (full scale deflection). Recheck the tuning with the lever key in this position for exact resonance (as indicated by a maximum deflection to the right) and, if necessary, reset the ΔQ zero.

d. Release the lever key and make the desired circuit change. Restore resonance to the circuit and again lift the lever key to the ΔQ position. Carefully recheck the tuning for resonance (minimum ΔQ reading) and read the change in Q on the ΔQ (red) scale. This value of ΔQ must be multiplied by the setting on the MULTIPLY Q BY meter. Release the lever key before making other changes.

If the change in Q exceeds the limit of the scale, the difference should be calculated arithmetically from the two Q values, viz., ΔQ = Q₁ - Q₂.

The parameters of the resistor are:

$$R_p = \frac{Q_1 Q_2}{\omega C_1 \Delta Q} \quad (\text{ohms}) \quad (5)$$

If the resistor is also reactive,

$$X_p = \frac{1}{\omega(C_2 - C_1)} \quad (\text{ohms}) \quad (\text{usually capacitive}) \quad (6)$$

$$\text{and } C_p = C_1 - C_2 \quad (\text{farads}) \quad (7)$$

If the resistor is inductive, (C₂ > C₁), the sign of Eq. (6) will be positive.

3. SMALL CAPACITORS.

Capacitors of less than about 430 micro-microfarads can be measured by a simple substitution method on the Q Meter.

a. Connect a work coil* to the COIL terminals and set the Q capacitor to a convenient value. Call this value C₁. If the capacitance of the test capacitor is known approximately, select a value of C₁ such that the difference between C₁ and the test capacitance falls between 30 and 100 μμf.

b. Adjust the frequency controls for circuit resonance. If the Q of the test capacitor is desired, proceed according to Section C-2, above. If the Q is not required, continue with the next step.

c. Connect the unknown capacitor to the CAP terminals and adjust the resonating capacitor to restore resonance. Note C₂. The parameters of the capacitor are:

$$C_p = C_1 - C_2 \quad (\text{farads}) \quad (7)$$

$$\text{and } Q = \frac{Q_1 Q_2 (C_1 - C_2)}{\Delta Q C_1} \quad (8)$$

*Unless the capacitance of the unknown capacitor requires investigation at a particular frequency, it is advisable to use a work coil that will resonate at 1.0 MC or less. Normal lead length will not affect the measured capacitance at these frequencies.

Values of capacitance less than 6 micro-microfarads can best be measured with the vernier capacitor using a procedure similar to that just described.

4. LARGE INDUCTORS.

Although large coils (say, greater than 100 millihenries), can be measured by the parallel method, other means are often more satisfactory. For example, using a frequency less than 50 KC with an external oscillator and/or external capacitance connected in parallel with the resonating capacitor while the inductor is connected in a normal manner to the COIL terminals.

As the measuring frequency approaches the self-resonant frequency of the coil, however, the parallel method must be used to measure the effective inductance just below resonance, the impedance at resonance, and the apparent capacitance above f_0 . Overtones in the coil can also be discovered by this means. Measurements made on a typical 1.0 millihenry r-f choke and a 250 microhenry coil are shown in Figure E.

The measuring procedure for the parallel connection of coils is similar to that described previously for

capacitors, but in this instance the resonating capacitance must usually be increased to restore resonance after the coil is connected to the CAP terminals.

a. Set the oscillator to the required measuring frequency.

b. If possible, select a work coil which will allow the measuring circuit to resonate at this frequency with a resonating capacitance of 30 to 70 $\mu\mu\text{f}$. For convenience only, adjust the main capacitor dial to the nearest round value and call this C_1 . Make the final adjustment for resonance with the vernier capacitor. Note: If the vernier is not changed during the measurement, its value will not affect the calculated effective inductance. When calculating the effective Q, however, the value of C_1 in the denominator of Eq. (8) must be the sum (or difference) of the readings on the main and vernier capacitor dials.

c. Connect the test coil to the CAP terminals and restore resonance by increasing the resonating capacitance. Note the value of C_2 .

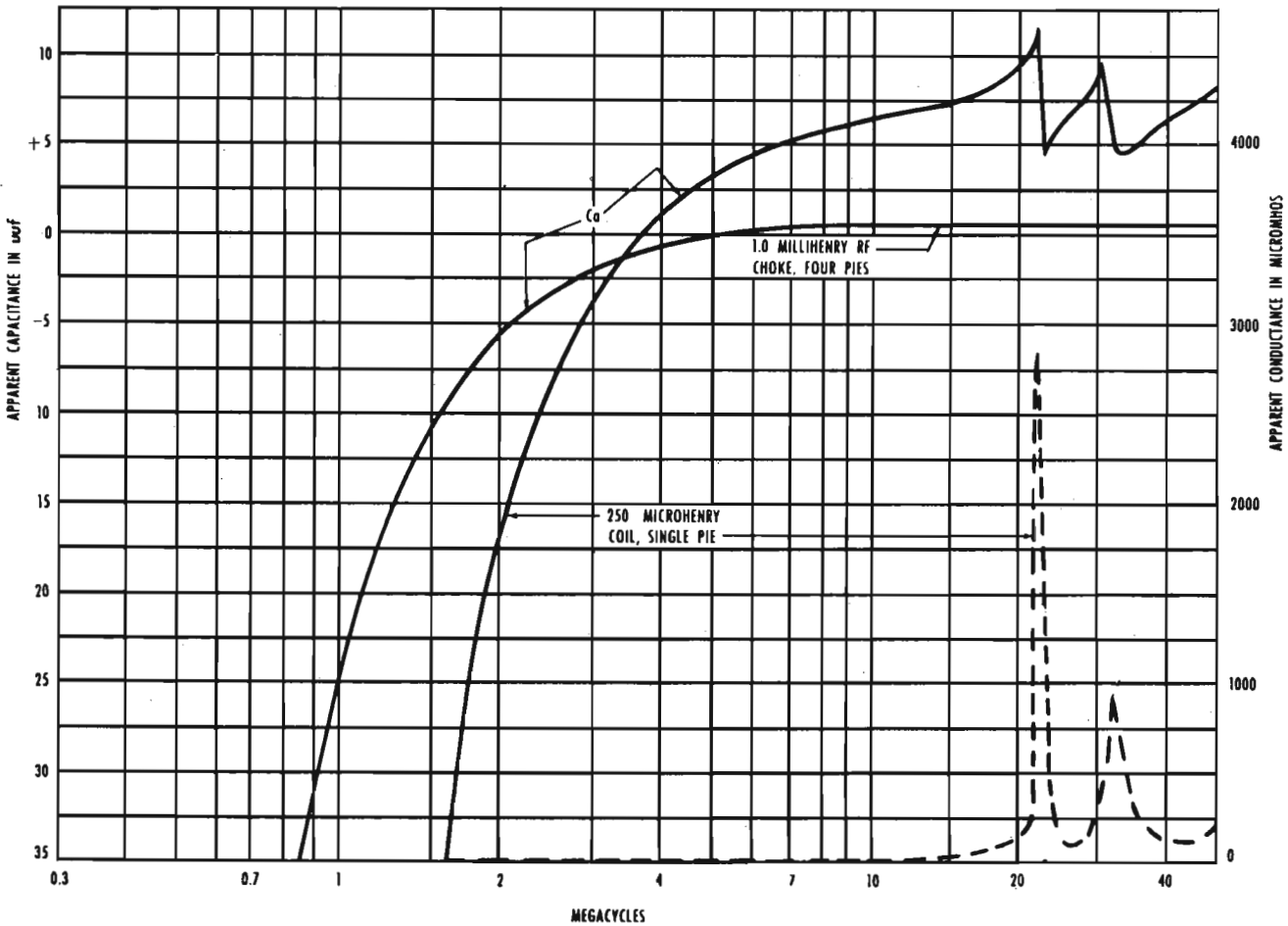

Figure E Apparent capacitance and conductance of two rf chokes in the vicinity of self-resonance

The inductance of the unknown coil is:

$$\text{effective inductance} = 1/\omega^2 (C_2 - C_1) \text{ (henries)} \quad (9)$$

and the effective Q equals,

$$\text{effective } Q = \frac{Q_1 Q_2 (C_2 - C_1)}{\Delta Q C_1} \quad (8)$$

If the measuring frequency, however, is greater than the self-resonant frequency of the coil, the coil under test will not appear inductive but is capacitive, and C_2 will be less than C_1 . A convenient expression for coils in the neighborhood of self-resonance and at frequencies greater than f_0 , is,

$$\text{apparent capacitance, } C_a = C_1 - C_2 \text{ (farads)}$$

Another useful expression for coils operating under these conditions is,

$$\text{apparent conductance, } G_a = \frac{\omega C_1 \Delta Q}{Q_1 Q_2} \text{ (mhos)}$$

The expression, *large*, used in this section is relative and a significant parallel measurement can be made with coils of only normal inductance, but which are designed to tune with values of capacitance less than the minimum 27 $\mu\mu\text{f}$ of the resonating capacitor. A great number of coils known as "peaking" coils fall in this category.

While the inductance of such coils can be found with the equation just given for effective inductance, it should be emphasized that an advantage of measuring coils by the "direct method", is that the capacitance required to tune the coil at the measuring frequency is given directly on the resonating capacitor dial. The distributed capacitance of the coil is taken into account with the "direct measurement".

If the capacitance required to tune a coil which normally resonates with less than 27 $\mu\mu\text{f}$ is desired, a direct measurement is impossible, due to the minimum resonant capacitance in the Q Meter measuring circuit. A parallel measurement, however, will yield the desired information, including the effects of distributed capacitance.

d. Proceed according to steps a., b., and c. above.

e. The capacitance required to tune the coil at the measuring frequency is simply,

$$C = C_2 - C_1$$

This measurement accounts for distributed capacitance and provides the same information with respect to tuning capacitance as would a direct connection to the COIL terminals.

D. SERIES MEASUREMENTS.

1. GENERAL.

Low impedance components, which include low value resistors, small coils, and large capacitors, are measured in series with the measuring circuit. Figure III-3 shows this connection. The specimen to be measured is placed in series with a reference coil between the LO

terminal and the low potential end of the reference coil. A heavy shorting strap should be employed to short-circuit the unknown component while a reference condition is established. The strap can then be opened, or removed, and the measuring circuit re-resonated. This procedure permits the specimen to be physically connected even though it is electrically out of the circuit and eliminates possible errors by maintaining the relative positions of the work coil and unknown component. If production measurements require this connection, it is advisable to construct a simple jig to provide terminals for the unknown specimens and a shorting plug to establish reference values of C, Q, and frequency. Such a jig will also facilitate laboratory measurements. Two 6-32 inserts are located near the measuring-circuit terminals for the mounting of special Q Meter jigs.

2. SMALL RESISTORS.

A small resistor connected in series with a work coil will lower the *indicated* Q and thus produce information for the calculation of the resistance. The higher this resistance, the greater the reduction of Q. The resistance must be sufficient to make ΔQ equal 5, but not large enough to reduce the *indicated* Q below 10. Within these limits, a range of resistance shown in Figure D can be measured.

The following procedure is recommended.

a. Set the oscillator controls to the desired measuring frequency. Adjust the XQ controls for a suitable MULTIPLY Q BY reading, preferably X1.

b. Connect a suitable work coil and the unknown resistor in series and place a shorting strap across the resistor. Connect the series combination to the COIL terminals with the strapped resistor next to the LO terminal.

The work coil should be selected so that larger resistors are measured with small values of resonating capacitance and smaller resistors are measured with large values of resonating capacitance.

c. Resonate the measuring circuit with the resistor shorted. Mentally note the value of Q_1 .

d. Set the ΔQ coarse control to the approximate value of Q_1 . Lift the lever key to the ΔQ position and adjust the fine ΔQ BALANCE control for a ΔQ reading of zero. Recheck the tuning with the lever key in this position for exact resonance (indicated by maximum deflection to the right). If necessary, reset the ΔQ zero.

e. Release the lever key and remove the short from across the resistor. Restore resonance and again lift the lever key to the ΔQ position. Carefully recheck the tuning for resonance and read the change in Q on the ΔQ (red) scale. Multiply this value by the reading on the MULTIPLY Q BY meter.

The parameters of the resistor are:

$$R_s = \frac{\left(\frac{C_1}{C_2}\right) Q_1 - Q_2}{\omega C_1 Q_1 Q_2} \text{ (ohms)} \quad (10)$$

If R_s is very small and Q_2 approximates Q_1 , it is recommended that the value of Q_2 be obtained by subtracting ΔQ from the measured value of Q_1 . The reactance of the resistor may be found from,

$$X_s = \frac{(C_1 - C_2)}{\omega C_1 C_2} \quad (\text{ohms}) \quad (11)$$

If the resistor is purely resistive, $C_2 = C_1$, the equation for resistance reduces to,

$$R_s = \frac{\Delta Q}{\omega C_1 Q_1 Q_2} \quad (\text{ohms})$$

Other equations can be found in Table I.

3. SMALL INDUCTORS.

Measurement of small coils at relatively low frequencies cannot be made directly at the COIL terminals. The following series method is recommended.

a. Set the oscillator controls to the desired measuring frequency.

b. Connect the unknown coil in series with the work coil, between the LO terminal and the low-potential end of the work coil. Provide a heavy shorting strap, which may be placed across the unknown coil.

c. With the shorting strap connected across the coil, adjust the resonating capacitor for resonance and note C_1 . The work coil selected should allow C_1 to be about 400 $\mu\mu\text{f}$.

d. Remove the short from across the unknown coil and restore resonance by decreasing the resonating capacitor. Note C_2 . The inductance may be found from,

$$L_s = \frac{(C_1 - C_2)}{\omega^2 C_1 C_2} \quad (\text{henries}) \quad (12)$$

If the Q of the coil is required, it may be calculated from,

$$Q = \frac{Q_1 Q_2 (C_1 - C_2)}{C_1 Q_1 - C_2 Q_2} \quad (13)$$

4. LARGE CAPACITORS.

The series measuring method is also suitable for the measurement of large capacitors. The procedure is similar to that given for small inductors with the following exceptions.

a. A large resistor should be connected across the unknown capacitor to provide a d-c grid return for the Q voltmeter tube. 10 megohms should be satisfactory for most applications.

b. The initial setting of resonating capacitance should be just low enough so that the addition of the unknown capacitor in series with the work coil will not require a value of C_2 greater than 460 $\mu\mu\text{f}$ in order to restore resonance to the measuring circuit. In general, C_1 need not be less than about 200 $\mu\mu\text{f}$.

c. The effective capacitance of the series capacitor may be calculated using the equation,

$$C_s = \frac{C_1 C_2}{(C_2 - C_1)} \quad (\text{farads}) \quad (14)$$

The Q of the capacitor may be found with Eq. (13).

This measuring technique is also convenient for finding the self-resonant frequency of by-pass capacitors. At that frequency the impedance of the capacitor is a minimum owing to series resonance between the capacitance and the lead inductance.

The self-resonant frequency of the capacitor can be found by alternately connecting and disconnecting the shorting strap while the frequency is increased in relatively large increments until a frequency is reached where C_2 (strap removed) is less than C_1 (capacitance shorted). Now decrease the frequency in smaller increments until C_2 equals C_1 . The impedance of the capacitor is resistive at this frequency (f_0) and equals,

$$R_s = \frac{\Delta Q}{\omega C_1 Q_1 Q_2} \quad (\text{ohms})$$

For example, a 0.01 μf paper tubular capacitor with 2 inch leads (total length) was found to be resonant at 5.2 MC. The impedance at this frequency was only 0.19 ohms (resistive).

E. RULES FOR THE CORRECTION OF ERRORS.

When circumstances call for measurements of a high degree of accuracy, the following corrections should be made in the order listed and partially corrected values used in each succeeding step.

1. DIRECT CONNECTION OF COILS.

a. Q and R_s

Correct *indicated* Q for:

(1) Q voltmeter conductance;

$$Q_n = \frac{Q_i}{1 - \frac{Q_i G_v}{\omega C}} \quad (5.4)$$

(Usually negligible if $C \geq 100 \mu\mu\text{f}$ and $Q \leq 150$, between 500 KC and 30 MC.)

(2) Insertion resistance:

$$Q_e = \frac{Q_i}{1 - \frac{\omega C Q_i}{50}}$$

(See Figure V-1 for limits of Q in error by 5 percent for attendant values of C and frequency.)

(3) Distributed capacitance;

$$C_{d1} = \frac{C_1}{\left(\frac{f_0}{f_1}\right)^2 - 1}$$

(See Figure A for a guide concerning the importance of C_{d1} .)

b. L

Correct the measured inductance for:

(1) Internal inductance;

$$L_c = L_{\text{meas.}} - L_m$$

(Requires correction only if $L \leq 0.5 \mu\text{h.}$)

(2) Distributed capacitance

$$\text{true inductance} = L_r \left(\frac{C}{C + C_d} \right)$$

(Usually negligible only if $L \leq 1.0 \mu\text{h.}$)

2. PARALLEL CONNECTION.

a. R_p

No correction needed below 20 MC. Above 20 MC, if the internal inductance, L_c , is not negligible compared with the effective inductance of the work coil, correct the value of resonating capacitance, C , for that portion of residual inductance which appears between the CAP terminals, using the following equation.

$$\text{effective capacitance} = \frac{C}{1 - \frac{\omega L_c}{\left(\frac{1}{\omega C}\right)}} = \frac{C}{1 - \omega^2 L_c C} \quad (15)$$

Use this value of effective capacitance in place of C in the equation

$$R_p = \frac{Q_1 Q_2}{\omega C_1 \Delta Q}$$

b. X_p , C_p , and L_p

No corrections needed, except as noted above for R_p . Values of both C_1 and C_2 should be corrected using equation 15 and substituting in the following:

$$X_p = \frac{1}{\omega(C_2 - C_1)}$$

$$C_p = C_1 - C_2, \text{ and}$$

$$L_p = \frac{1}{\omega^2(C_2 - C_1)}$$

c. Q

Same as for X_p .

3. SERIES CONNECTION.

a. R_s

Same as for R_p . Use effective capacitance in place of C in the equation

$$R_s = \frac{\left(\frac{C_1}{C_2}\right) Q_1 - Q_2}{\omega C_1 Q_1 Q_2}$$

b. X_s , L_s , and C_s

Same as for X_p . When necessary, use effective values of C_1 and C_2 in the following:

$$X_s = \frac{C_1 - C_2}{\omega C_1 C_2}$$

$$L_s = \frac{C_1 - C_2}{\omega^2 C_1 C_2}$$

$$C_s = \frac{C_1 C_2}{C_2 - C_1}$$

The distributed capacitance of a test coil that requires measurement by the series method is usually so small that the true inductance and effective inductance of the coil are essentially equal at the measuring frequency. In a few cases, however, correction may be necessary.

c. Q

Same as for X_p .

TABLE I
FORMULAS FOR CALCULATING Q AND IMPEDANCE
PARAMETERS FROM PARALLEL AND SERIES MEASUREMENTS

Parallel Measurements

Effective Q of Unknown

$$Q = \frac{Q_1 Q_2 (C_2 - C_1)}{\Delta Q C_1} \quad (8)$$

Effective Parallel Resistance of Unknown

$$R_p = \frac{Q_1 Q_2}{\omega C_1 \Delta Q} \quad (5)$$

Effective Parallel Reactance of Unknown

$$X_p = \frac{1}{\omega (C_2 - C_1)} \quad (6)$$

Effective Parallel Inductance of Unknown

$$L_p = \frac{1}{\omega^2 (C_2 - C_1)} \quad (9)$$

Effective Parallel Capacitance of Unknown

$$C_p = C_1 - C_2 \quad (7)$$

Note 1: In Eq. (6) the sign of the quantity $(C_2 - C_1)$ indicates the type of effective reactance. A positive quantity results from an inductive reactance and a negative sign from a capacitive reactance.

Note 2: Disregard the sign of the quantity $(C_2 - C_1)$ in Eq. (8) above.

Series Measurements

Effective Q of Unknown

$$Q = \frac{Q_1 Q_2 (C_1 - C_2)}{C_1 Q_1 - C_2 Q_2} \quad (13)$$

Effective Series Resistance of Unknown

$$R_s = \frac{\left(\frac{C_1}{C_2}\right) Q_1 - Q_2}{\omega C_1 Q_1 Q_2} \quad (10)$$

Effective Series Reactance of Unknown

$$X_s = \frac{C_1 - C_2}{\omega C_1 C_2} \quad (11)$$

Effective Series Inductance of Unknown

$$L_s = \frac{C_1 - C_2}{\omega^2 C_1 C_2} \quad (12)$$

Effective Series Capacitance of Unknown

$$C_s = \frac{C_1 C_2}{C_2 - C_1} \quad (14)$$

Note 1: In Eq. (11) the sign of the quantity $(C_1 - C_2)$ indicates the type of effective reactance. A positive quantity results from an inductive reactance and a negative sign from a capacitive reactance.

Note 2: Disregard the sign of the quantity $(C_1 - C_2)$ in Eq. (13) above.

TABLE II
FORMULAS RELATING SERIES AND PARALLEL COMPONENTS

$$Q = \frac{X_s}{R_s} = \frac{\omega L_s}{R_s} = \frac{1}{\omega C_s R_s} = \frac{R_p}{X_p} = \frac{R_p}{\omega L_p} = R_p \omega C_p = \sqrt{\frac{L}{C}} = \frac{R_p}{\sqrt{\frac{L}{C}}}$$

General Formulas	Formulas for Q greater than 10	Formulas for Q less than 0.1	General Formulas	Formulas for Q greater than 10	Formulas for Q less than 0.1
$R_s = \frac{R_p}{1 + Q^2}$	$R_s = \frac{R_p}{Q^2}$	$R_s = R_p$	$R_p = R_s(1 + Q^2)$	$R_p = R_s Q^2$	$R_p = R_s$
$X_s = X_p \frac{Q^2}{1 + Q^2}$	$X_s = X_p$	$X_s = X_p Q^2$	$X_p = X_s \frac{1 + Q^2}{Q^2}$	$X_p = X_s$	$X_p = \frac{X_s}{Q^2}$
$L_s = L_p \frac{Q^2}{1 + Q^2}$	$L_s = L_p$	$L_s = L_p Q^2$	$L_p = L_s \frac{1 + Q^2}{Q^2}$	$L_p = L_s$	$L_p = \frac{L_s}{Q^2}$
$C_s = C_p \frac{1 + Q^2}{Q^2}$	$C_s = C_p$	$C_s = \frac{C_p}{Q^2}$	$C_p = C_s \frac{Q^2}{1 + Q^2}$	$C_p = C_s$	$C_p = C_s Q^2$

BIBLIOGRAPHY

Many measuring techniques have evolved around the Q Meter since its introduction by the Boonton Radio Corporation in 1934. While these measurements are too specialized to present in an instruction book, it was considered desirable to include a bibliography of Q Meter measurements and related subjects. We will welcome having any omissions brought to our attention and invite correspondence concerning new applications for Q Meters.

The Boonton Radio Corporation is indebted to those engineers and technicians whose contributions to the literature have advanced the art of Q Meter measurements and wish to offer our thanks to the entire engineering profession for the world-wide acceptance given to BRC Q Meters.

GENERAL Q METER THEORY (CALIBRATION AND CORRECTION OF ERRORS)

V. V. K. Rao, "The Q Meter and Its Theory," Proc. I.R.E., p. 502; Nov., 1942.

I. Bady, "Calibration of Q Meter, Model 160-A," Signal Corps Report, March, 1943.

W. F. Lovering, "On the Measurement of the Residual Parameters of a Q Meter," Philo. Mag., Feb., 1944.

Aircraft Radio Laboratory Engineering Report No. 371 (War Department), "Derivation of Q Meter Formulae and Limits of Application to Fixed Frequency Impedance Measurements," August, 1944.

D. M. Hill, "Measurement of the Internal Inductance of the Q Meter Circuit of the 160-A Q Meter," BRC Report No. 1549, Oct., 1944.

I. Bady, "Notes on Increasing the Accuracy and Usefulness of the Boonton Q Meter Model 160-A," Signal Corps Report, Sept., 1945.

G. F. Barnett, "Method for Extending Range of Q Meter," Elect. World, p. 78, March, 1946.

H. G. M. Spratt, "Q Meters," Wireless World, p. 7, Jan., 1949.

A. C. Lynch, "Improved Accuracy with a Q Meter by the Use of Auxiliary Components," Elect. Eng., p. 91, March, 1949.

Cathode Ray, "Q — How Many Kinds Are There?," Wireless World, p. 267, July, 1949.

R. E. Lafferty, "Q Meter Correction Chart for Q Voltmeter Loading," p. 43, Tele-Tech, Oct., 1952.

R. E. Lafferty, "Q Meter Correction Chart for Distributed Capacitance," p. 63, Tele-Tech, Nov., 1952.

Bureau of Standards Circular C-47, "Radio Instruments and Measurements," p. 133.

R. F. Field and D. B. Sinclair, "A Method for Determining the Residual Inductance and Resistance of a Variable Air Condenser at Radio Frequencies," Proc. I.R.E., Feb., 1936.

R. G. Medhurst, "HF Resistance and Self-Capacitance of Single-Layer Solenoid," Wireless Engineer, Feb. and March, 1947.

Q MEASUREMENTS

C. J. Franks, "Values of Q for Various Component Parts," Electronics, p. 126, April, 1935.

A. W. Barber, "The Resultant Q of Tuned Circuits," Radio Eng., July, 1937.

I. Bady, "Measurement of Q of High Capacity Condensers by the Series-Parallel Method," Signal Corps Report, March, 1943.

E. L. Hall, "VHF Behavior of Radio Components," Electronics, March, 1944.

L. E. Pepperberg, "Determining Q of Capacitors," Electronics, p. 146, Sept., 1945.

R. S. Naslund, "Optimum Q and Impedance of RF Inductors," QST, July, 1941.

"Nomograph for Q Meter," Electr. Ind., p. 90, Sept., 1945.

W. J. Spaven, "High Q Measurement," Electronics, p. 166, Nov., 1952.

INDUCTANCE AND IRON CORES

E. Measing, "Coil Testing Methods for Use in Radio Plants," Electronics, p. 248, August, 1935.

D. Pollack, "The Design of Inductance for Frequencies Between 4 and 25 mc," Electrical Eng., Sept., 1937.

D. E. Foster and A. E. Newlon, "Measurement of Iron Cores at Radio Frequencies," Proc. I.R.E., p. 266, May, 1941.

W. J. Polydoroff and A. J. Klapperich, "Effective Permeability of High Frequency Iron Cores," Radio, p. 38, Nov., 1945.

A. I. Forbes Simpson, "The Design of Small Single Layer Coils," Electrical Eng., p. 353, Nov., 1947.

"Basic Theory for Ohmite Frequency Rated RF Chokes," Ohmite News, Feb., 1948.

R. E. Lafferty, "Extended Q Meter Measurements," Electronics, Nov., 1951.

E. Both, "Magnetic Powdered Cores for Military Communication," Tele-Tech, p. 36, August, 1952.

National Bureau of Standards Technical Bulletin, "Calibration of Magnetic Materials," Tele-Tech, Jan., 1953.

W. J. Polydoroff, "Powdered Magnetic Cores," Tele-Tech, p. 69, Feb., 1953.

W. T. Cocking, "Q and Inductance," Wireless World, Nov. and Dec., 1949.

H. A. Wheeler, "Inductance Chart for Solenoid Coil," Proc. I.R.E., p. 1398, Dec., 1950.

General Aniline and Film Corp. Brochure, "Bibliography on Iron Cores."

Peter H. Haas, "A Radio-Frequency Permeameter," Journal of Research of the National Bureau of Standards, p. 221, Vol. 51, No. 5, November, 1953.

CAPACITANCE AND DIELECTRIC MEASUREMENTS

H. A. Snow, "Losses in Mica and Simple Test Procedure," Radio Eng., Feb., 1937.

A. W. Barber, "Simplified Dielectric Loss Measurements," Radio Eng., July, 1937.

J. R. Townsend, "Testing, Grading, Classifying, and Quality Control of Mica," BTL, August, 1943.

D. M. Hill, "Q Meter for Power Factor and Dielectric Constant," Electr. World, Oct., 1943.

JAN-C-5 Specification: "Capacitors, Mica-Dielectric, Fixed," Nov., 1944.

I. Bady, "Notes on Increasing the Accuracy and Usefulness of the Boonton Q Meter, Model 160-A," Signal Corps Report, Sept., 1945.

T. Hazen, "Dielectric Properties vs. Temperature of Thermosetting Molding Preforms at Radio Frequencies," Electrochem. Soc., Vol. 9, p. 1443, 1946.

BOONTON RADIO CORPORATION

K. G. Coutlee, "Judging Mica Quality Electrically," *Trans. A.I.E.E.*, Vol. 64, pp. 735-740.

G. N. Howatt, "Dielectric Properties of Steatite Porcelain," *Jour. Am. Ceramic Soc.*, May, 1946.

A. P. Wangsgard and T. Hazen, "The Q Meter for Dielectric Measurement on Polyethylene and Other Plastics at Frequencies up to 50 mc," *Electrochem. Soc.*, Vol. 90, pp. 361-375, Oct., 1946.

Amer. Soc. for Testing Materials, D-150: "Power Factor and Dielectric Constant of Electrical Insulating Materials."

A. H. Scott and H. L. Curtis, "Edge Correction in the Determination of Dielectric Constant," *Jour. of Research, Nat. Bureau of Standards*, Vol. 22, pp. 747-775, June, 1939.

J. F. Price, "Effectiveness of By-Pass Capacitors at VHF," *Comm. Feb.*, 1948.

E. W. Greenfield, "Refresher for Dielectric Calculations," *Electrical Eng.*, Oct., 1943.

RESISTANCE

I. Bady, "Notes on Increasing the Accuracy and Usefulness of the Boonton Q Meter, Model 160-A," *Signal Corps Report*, Sept., 1945.

R. E. Lafferty, "Extended Q Meter Measurements," *Electronics*, Nov., 1951.

R. Miedke, "Q Meter Impedance Charts," *Electronics*, p. 112, Jan., 1950.

H. A. Wheeler, "Formulas for Skin Effect," *Proc. I.R.E.*, Sept., 1942.

R. G. Medhurst, "HF Resistance and Self-Capacitance of Single-Layer Solenoids," *Wireless Eng.*, Feb. and Mar., 1947.

TRANSFORMERS

L. E. Pepperberg, "Coupling Coefficient Chart," *Electronics*, July, 1945.

"Q Meter Method of Determining Actual Coupling to Critical Coupling in IF Transformer," *JWL of TWA, Radio Engrg. Rpt. No. RER14*, Aug. 45.

S. G. Feldman and M. Goldstein, "Measuring Coupling Coefficients in Tuned RF Transformers," *Electronics*, Dec., 1950.

R. E. Lafferty, "RF Coupling Nomograph," *Electronics*, p. 166, Oct., 1952.

P. M. Honnell, "Note on Measuring Coupling Coefficient," *Radio*, p. 41, Feb., 1945.

C. B. Aiken, "Two-Mesh Coupled Circuit Filters," *Proc. I.R.E.*, Feb., 1937.

"Inductive Coupling of RF Coils," *BRC Report*, April, 1953.

TRANSMISSION LINES

Ballantine Laboratories, "Measurement of High Frequency Lines," *Electronics*, April, 1938.

C. Stewart, Jr., "The S Function Method of Measuring Attenuation of Coaxial Radio Frequency Cable," *Technical Paper A.I.E.E.* 45-134, Oct., 1944.

C. Stewart, Jr., "A Method of Measuring Attenuation of Short Lengths of Coaxial Cable," *Proc. I.R.E.*, p. 946, Jan., 1945.

C. C. Fleming, "Measuring Coaxials at Ultra High Frequencies," *BTL, Bell Labs Record*, Jan., 1946.

ANTENNAS

G. L. Haller, "Constants of Fixed Antennas on Aircraft," *Proc. I.R.E.*, April, 1938.

G. L. Haller, "Aircraft Antennas," *Proc. I.R.E.*, p. 357, August, 1942.

E. F. Kiernan, "Transport Aircraft Antenna Characteristics," *Electronics*, Dec., 1944.

W. S. Bachman, "Loop Antenna Coupling Transformer Design," *Proc. I.R.E.*, p. 865, Dec., 1945.

J. E. Browder and V. J. Young, "Design Values for Loop-Antenna Input Circuits," *Proc. I.R.E.*, May, 1947.

E. M. Kendell, "Receiver Loop - Antenna Design Factors," *Comm. Nov.*, 1945.

SPECIAL MEASUREMENTS

B. N. Prakash, "On the Measurement of Negative Impedances with a Q Meter," *Electrotechniques*, pp. 69-73, Dec., 1946.

H. A. Bierwirth and C. N. Hoyler, "Radio Frequency Heating Applied to Wood Gluing," *Proc. I.R.E.*, Oct., 1943.

W. D. George, M. C. Selby, and R. Scolink, "Precision Measurement of Electrical Characteristics of Quartz Crystal Units," *Proc. I.R.E.*, p. 1122, Sept., 1948.

ELECTRICAL COMPONENTS

OSCILLATOR

SYMBOL	BRC PART NO.	DESCRIPTION
C-101	82216	Capacitor, fixed; mica; 250 μmf ; $\pm 10\%$; 500 VDCW; button type
C-102	82115	Capacitor, fixed; ceramic; 47 μmf ; $\pm 2.5\%$; NPO; 600 VDCW
C-103	84089	Capacitor, variable; pyrex tubular; 1-8 μmf
C-104	82114	Capacitor, fixed; ceramic; 33 μmf ; $\pm 2.5\%$; NPO; 600 VDCW
C-105	84090	Capacitor, variable; pyrex tubular; 1-12 μmf
C-106	82428	Capacitor, fixed; Hi K ceramic; .01 μf ; $+80\%$, -20% ; 600 VDCW
C-107	82306	Capacitor, fixed; Hi K ceramic; 1000 μmf ; $+80\%$, -20% ; 600 VDCW
C-108	82216	Capacitor, fixed; mica; 250 μmf ; $\pm 10\%$; 500 VDCW; button type
C-109	82114	Capacitor, fixed; ceramic; 33 μmf ; $\pm 2.5\%$; NPO; 600 VDCW
C-110	84090	Capacitor, variable; pyrex tubular; 1-12 μmf
C-111	82132	Capacitor, fixed; ceramic; 47 μmf ; $\pm 5\%$; N330; ± 500 PPM
C-112	84089	Capacitor, variable; pyrex tubular; 1-8 μmf
C-113	82306	Capacitor, fixed; Hi K ceramic; 1000 μmf ; $+80\%$, -20% ; 600 VDCW
C-114	82216	Capacitor, fixed; mica; 250 μmf ; $\pm 10\%$; 500 VDCW; button type
C-115	82033	Capacitor, fixed; ceramic; 22 μmf ; $\pm 2\%$; NPO; ± 60 PPM; 500 VDCW
C-116	84090	Capacitor, variable; pyrex tubular; 1-12 μmf
C-117	82132	Capacitor, fixed; ceramic; 47 μmf ; $\pm 5\%$; N330; ± 500 PPM
C-118	82000	Capacitor, fixed; ceramic; 5 μmf ; $\pm 5\%$; ± 2 PPM
C-119	84090	Capacitor, variable; pyrex tubular; 1-12 μmf
C-120	82120	Capacitor, fixed; ceramic; 100 μmf ; $\pm 20\%$; 350 VDCW
C-121	82000	Capacitor, fixed; ceramic; 5 μmf ; $\pm 5\%$; ± 2 PPM
C-122	84090	Capacitor, variable; pyrex tubular; 1-12 μmf
C-123	82117	Capacitor, fixed; ceramic; 68 μmf ; $\pm 20\%$; 500 VDCW
C-124	82010	Capacitor, fixed; ceramic; 10 μmf ; $\pm 10\%$
C-125	84089	Capacitor, variable; pyrex tubular; 1-8 μmf
C-126	B301691	Capacitor, variable; air; dual; 12.5-480 μmf ; 9.5-240 μmf
C-127	82033	Capacitor, fixed; ceramic; 22 μmf ; $\pm 2\%$; NPO; ± 60 PPM; 500 VDCW
C-128	83001	Capacitor, fixed; mica; 0.1 μf ; $\pm 10\%$; 400 VDCW
C-129	A300552	Capacitor, variable; air; 1.8 to 8.6 μmf
C-130	82428	Capacitor, fixed; Hi K ceramic; .01 μf ; $+80\%$, -20% ; 600 VDCW
C-131	82318	Capacitor, fixed; feed through ceramicon; 1500 μmf ; $\pm 20\%$
C-132	82318	Capacitor, fixed; feed through ceramicon; 1500 μmf ; $\pm 20\%$
C-133	82318	Capacitor, fixed; feed through ceramicon; 1500 μmf ; $\pm 20\%$
C-134	82318	Capacitor, fixed; feed through ceramicon; 1500 μmf ; $\pm 20\%$
L-101	A85537	Choke, RF; 12 μhy
L-102	A85592	Choke, RF; 50 μhy
R-101	80186	Resistor; fixed; composition; 1000 Ω ; $\pm 10\%$; $\frac{1}{2}$ W
R-102	80143	Resistor; fixed; composition; 680 Ω ; $\pm 10\%$; $\frac{1}{2}$ W
R-103	80279	Resistor; fixed; composition; 3300 Ω ; $\pm 10\%$; 1 W
R-104	80385	Resistor; fixed; composition; 10 K Ω ; $\pm 10\%$; $\frac{1}{2}$ W
R-105	80332	Resistor; fixed; composition; 10 K Ω ; $\pm 10\%$; 1 W
R-106	80186	Resistor; fixed; composition; 1000 Ω ; $\pm 10\%$; $\frac{1}{2}$ W
R-107	80143	Resistor; fixed; composition; 680 Ω ; $\pm 10\%$; $\frac{1}{2}$ W
R-108	80530	Resistor; fixed; composition; 150 K Ω ; $\pm 10\%$; 1 W
R-109	80562	Resistor; fixed; composition; 68 K Ω ; $\pm 10\%$; 1 W
R-110	80527	Resistor; fixed; composition; 150 K Ω ; $\pm 5\%$; $\frac{1}{2}$ W
R-111	80279	Resistor; fixed; composition; 3300 Ω ; $\pm 10\%$; 1 W
R-112	80186	Resistor; fixed; composition; 1000 Ω ; $\pm 10\%$; $\frac{1}{2}$ W
R-113	80143	Resistor; fixed; composition; 680 Ω ; $\pm 10\%$; $\frac{1}{2}$ W
R-114	80562	Resistor; fixed; composition; 68 K Ω ; $\pm 10\%$; 1 W
R-115	80273	Resistor; fixed; composition; 1500 Ω ; $\pm 5\%$; $\frac{1}{2}$ W

BOONTON RADIO CORPORATION

OSCILLATOR (Continued)

SYMBOL	BRC PART NO.	DESCRIPTION
R-116	80332	Resistor; fixed; composition; 10 K Ω ; $\pm 10\%$; 1 W
R-117	80562	Resistor; fixed; composition; 68 K Ω ; $\pm 10\%$; 1 W
R-118	80273	Resistor; fixed; composition; 1500 Ω ; $\pm 5\%$; 1/2 W
R-119	80273	Resistor; fixed; composition; 1500 Ω ; $\pm 5\%$; 1/2 W
R-120	80062	Resistor; fixed; composition; 100 Ω ; $\pm 5\%$; 1/2 W
R-121	80190	Resistor; fixed; composition; 220 Ω ; $\pm 10\%$; 1 W
R-122	80032	Resistor; fixed; composition; 33 Ω ; $\pm 5\%$; 1/2 W
R-123	A80516	Resistor; fixed; composition; 100 K Ω ; $\pm 10\%$; 1/2 W
R-124	A80170	Resistor; fixed; composition; 470 Ω ; $\pm 5\%$; 1/2 W
V-101		5763 tube

Q CIRCUIT

C-201A,		
C-201B	C301752	Capacitor, variable; air; 30-460 μf
C-202	82428	Capacitor, fixed; Hi K ceramic; .01 μf ; +80%, -20%; 600 VDCW
C-203	82428	Capacitor, fixed; Hi K ceramic; .01 μf ; +80%, -20%; 600 VDCW
J-201	301742	Connector, female; UG-535/U
M-201	B301416	Meter; "Multiply Q by"
P-201	A94156	Connector, male; UG-88/U
R-201	A80673	Resistor, fixed; 100 megohm; $\pm 15\%$ at DC
R-202	A301887	Resistor, fixed; Annular type; .02 Ω ; $\pm 1\%$
R-203	80015	Resistor, fixed; WW; $\pm 1\%$ (to be selected)
R-204	80015	Resistor, fixed; WW; $\pm 1\%$ (per spec. # A302229)
TC-201	565-A	Thermocouple Unit

Q VOLTMETER

C-301	83071	Capacitor, fixed; flat plate ceramic; 0.1 μf ; +80%, -20%; 600 VDCW
C-302	83019	Capacitor, fixed; metallized paper; 0.1 μf ; +30%, -20%; 200 VDCW
M-301	B301415	Meter, "Circuit Q"
R-301	80498	Resistor, fixed; WW; 22 K Ω ; $\pm 1\%$; 1/2 W
R-302	80295	Resistor, fixed; WW; 3.5 K Ω ; $\pm 1\%$; 1/2 W
R-303	A80148	Resistor, fixed; composition; 1000 Ω ; $\pm 5\%$; 1/2 W
R-304	80294	Resistor, fixed; film type; 1300 Ω ; $\pm 2\%$; 1/2 W
R-305	80419	Resistor, fixed; WW; 32 K Ω ; $\pm 1\%$; 1 W
R-306	A81211	Resistor, variable; WW; 3 K Ω ; 2 W
R-307	A81217-2	Resistor, variable; WW; 1500 Ω , 50 Ω , 50 Ω triple section
R-308	A81211	Resistor, variable; WW; 3 K Ω ; 2 W
R-309	80499	Resistor, fixed; WW; 39 K Ω ; $\pm 1\%$; 1/2 W
R-310	A81330	Resistor, variable; WW; 10 K Ω ; 2 W
R-311	A81122	Resistor, variable; WW; 200 Ω
R-312	A81123	Resistor, variable; WW; 750 Ω ; SDA serial # 206 and up
R-312	80129	Resistor, fixed; composition; 510 Ω ; 1/2 W; serial # 6 through 205
S-301	A301758	Switch, Lever General Control MCT-1 P-3
V-301	91004-1	BRC Type 535-A (Supersedes 105-A)

Q METER TYPE 260-A

POWER SUPPLY

SYMBOL	BRC PART NO.	DESCRIPTION
C-401	83102	Capacitor, fixed; electrolytic; 40 μ f; 450 VDCW
F-401	93667	Fuse holder
	95011	Fuse, 1 ampere; type 3AG
I-401	A 303876	Lamp socket, miniature bayonet
	90904	Lamp S-47
J-401	301754	Socket, 6 prong; Jones # S-306-AB
J-402	301755	Socket, 4 prong; Jones # S-304-AB
L-401	A301769	Filter choke; 10 hy; 80 ma; 240 ohms
P-401	301749	Connector, male; Jones P-306-CCT; 6 prong
P-402	301756	Connector, male; Jones P-304-CCT; 4 prong
R-401	80389	Resistor, fixed; composition; 4.7 K Ω ; $\pm 5\%$; 2 W
R-402	80420	Resistor, fixed; composition; 33 K Ω ; $\pm 5\%$; 2 W
R-403	80420	Resistor, fixed; composition; 33 K Ω ; $\pm 5\%$; 2 W
R-404	A81211	Resistor, variable; WW; 3 K Ω ; 2 W; SDA
R-405	A81418	Resistor, variable; WW; dual 40 K; $\pm 10\%$; 40 W; w/switch
T-401	B301757	Transformer, power
V-401		6X4 Tube
V-402		0B2 tube
V-403		0A2 tube
VR-401	A85028	Voltage stabilizer

Q CIRCUIT

VOLTMETER CIRCUIT

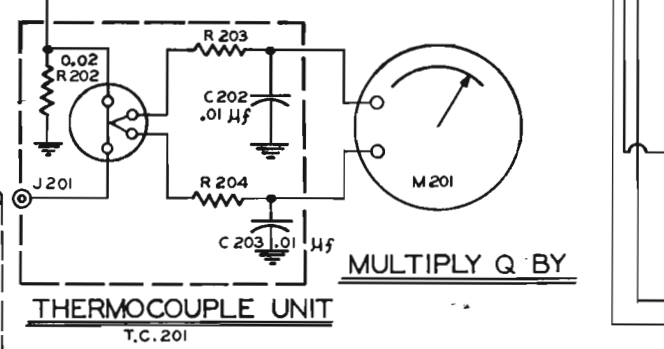
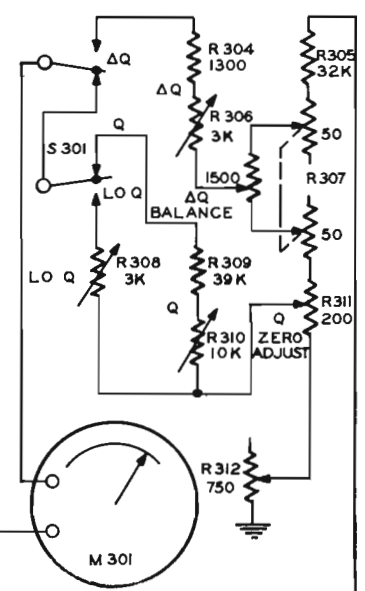
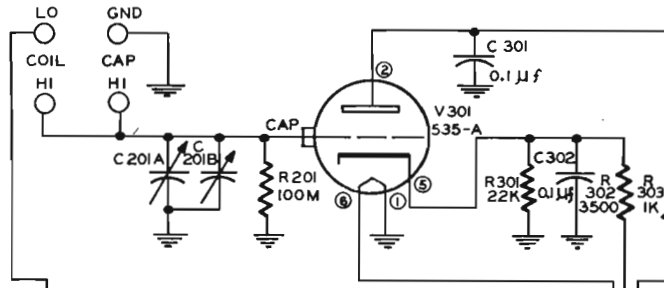
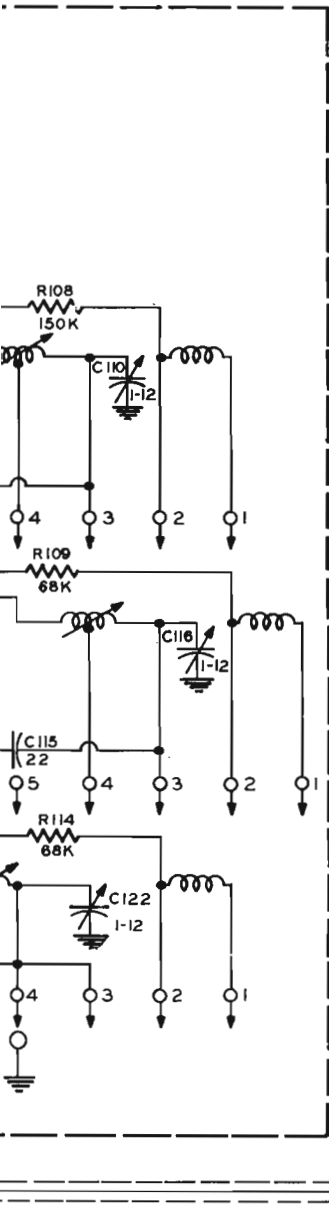

CIRCUIT Q

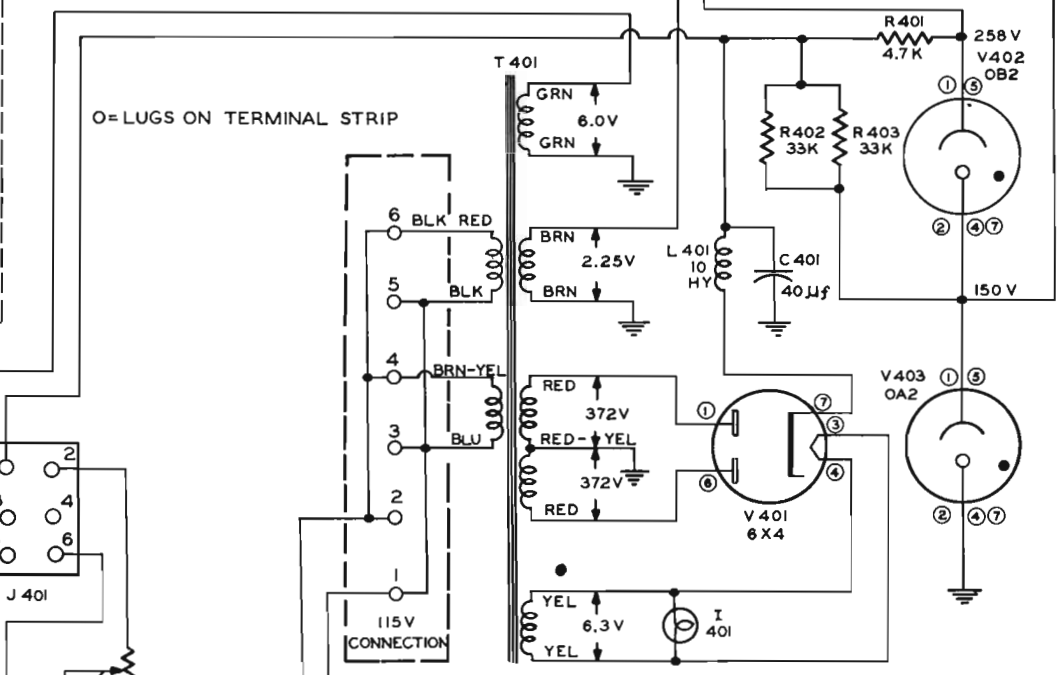

POWER SUPPLY
INPUT 95-130V, 60~ (260A)
(SEE INSET #1 FOR 260AP)

NOTES

CAPACITANCE IN μUF UNLESS OTHERWISE NOTED.
RESISTANCE IN OHMS.
K = 1,000 OHMS.
M = 1,000,000 OHMS.

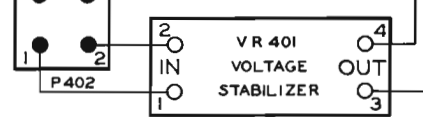
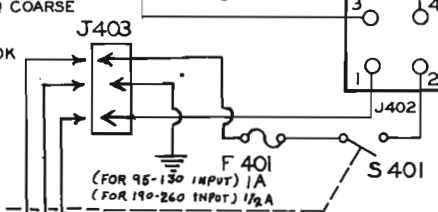
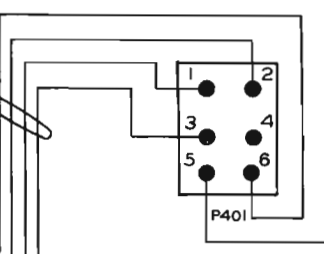

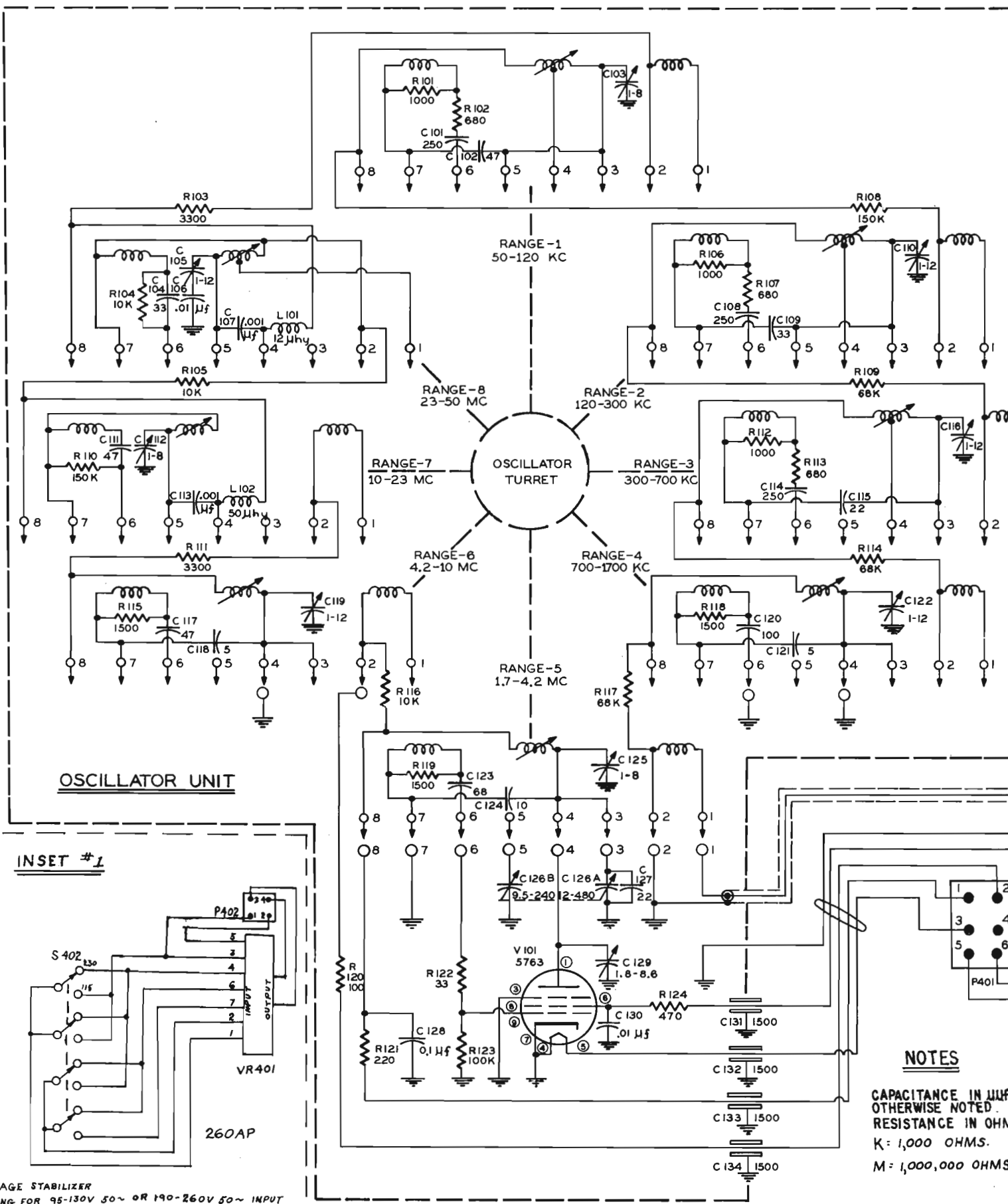

OSCILLATOR UNIT

INSET #1

NOTES

CAPACITANCE IN μ F
 OTHERWISE NOTED.
 RESISTANCE IN OHMS.
 K = 1,000 OHMS.
 M = 1,000,000 OHMS

VOLTAGE STABILIZER
 WIRING FOR 95-130V 50~ OR 190-260V 50~ INPUT
 S402 SHOWN IN 190-260V POS.
 VR401 50~ REPLACES VR401 60~

Measurement Procedures for Inductance and Q

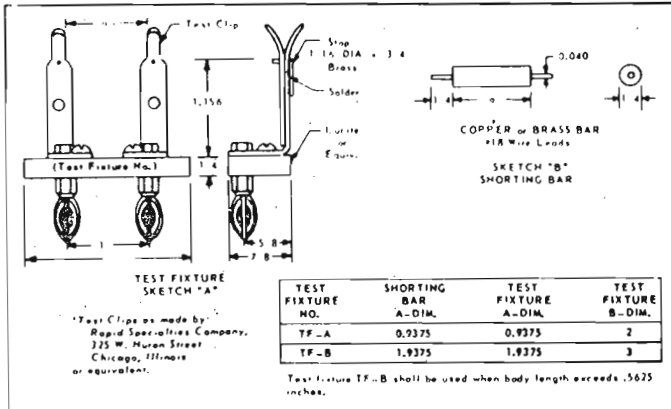

The use of procedures as outlined in MIL-C-15305 for the measurement of inductance and Q will greatly assist the user in establishing consistent and reproducible measurements. The initiating of these procedures for incoming tests and inspections will also result in a minimum of time being expended to establish correlation between supplier and user. This technique should be used for commercial and industrial inductor procurement and not restricted to military applications alone. Inductance and Q of inductors are measured using one of the procedures below:

PROCEDURE A:

Inductance and Q Measurements for Inductance Values 0.10 Microhenry to 10 Microhenries inclusive.

1. Equipment:

- Boonton Radio Corporation Type 260A Q-Meter, or equivalent.
- Test fixtures made according to Sketch "A".
- Shorting bars made according to Sketch "B".
- Frequency meter capable of monitoring Q-Meter frequencies to at least $\pm 0.1\%$ accuracy.

P.N.# 7938714

CHOKE - ANT

AIRCO Electronics

SALES OFFICES AND MANUFACTURING PLANTS LOCATED:

AIRCO ELECTRONICS
P. O. Box 547
Bradford, Pennsylvania 16701
Phone: (814) 362-5536

AIRCO ELECTRONICS
P. O. Box 1692
Nogales, Arizona 85621
Phone: (602) 287-5851

2. Inductance Measurement:

- Install test fixture in Q-Meter COIL terminals with side showing fixture numbers facing "CAP" terminals.
- Insert appropriate shorting bar in test fixture, seating it firmly against stops on clips.
- Set Q-Meter capacitor at 400 mmf. and vernier at zero.
- Follow procedures outlined in Type 260A Q-Meter Manual for operation of Q-Meter. Locate and record in MC/s the resonant frequency f (approx. 30.5 MC/s for TFA Test Fixture). Monitor Q-Meter frequency if necessary, to obtain an accuracy of $\pm 0.1\%$ or better.
- Calculate the sum of internal Q-Meter inductance, plus test fixture inductance, from $L(\text{uh}) = \frac{63.2}{f^2} - 0.008$ (0.008 uh is the calculated inductance of the shorting bar for TFA Test Fixture from Formula 132 of Bureau of Standards Circular 74). The sum is approximately 0.06 uh for TFA Test Fixture and 0.09 uh for TFB Test Fixture.
- Remove shorting bar.
- Insert inductor to be measured in test fixture. Seat leads firmly against stops on clips, and approximately center inductor body between clips.
- Set Q-Meter at appropriate direct reading measurement frequency to $\pm 0.1\%$ or better.
- Resonate circuit with Q-Meter capacitor.
- Record inductance as read on inductance dial. (This is total effective inductance of Q-Meter, test fixture, and inductor).
- Calculate effective inductance of inductor alone by subtracting value obtained in Step (e) from value obtained in Step (j).

3. Q Measurement:

Measure Q of inductors using procedure outlined in Section III Para. E-2 of the Type 260 A Q-Meter Instruction Manual, except inductor should be measured while mounted in test fixture as for inductance measurement in (2) above.

PROCEDURE B:

Inductance and Q Measurements for Inductance Values above 10 Microhenries:

- Measure inductance as in Procedure A (2) above, except do not make allowance for internal inductance of Q-Meter or test fixture.
- Measure Q of inductors as outlined in Procedure A (3) above.

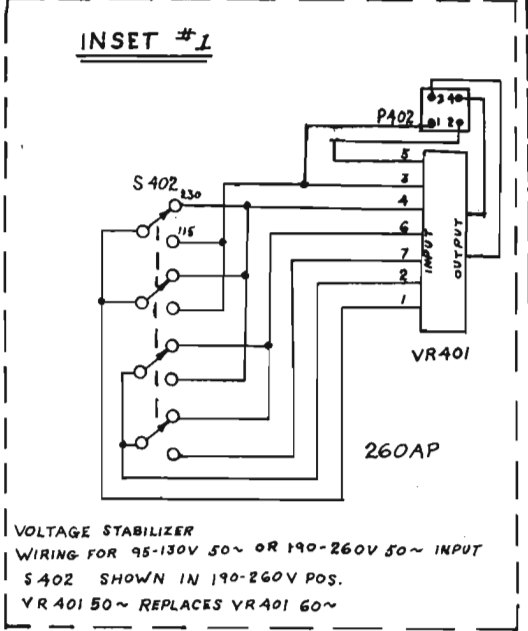
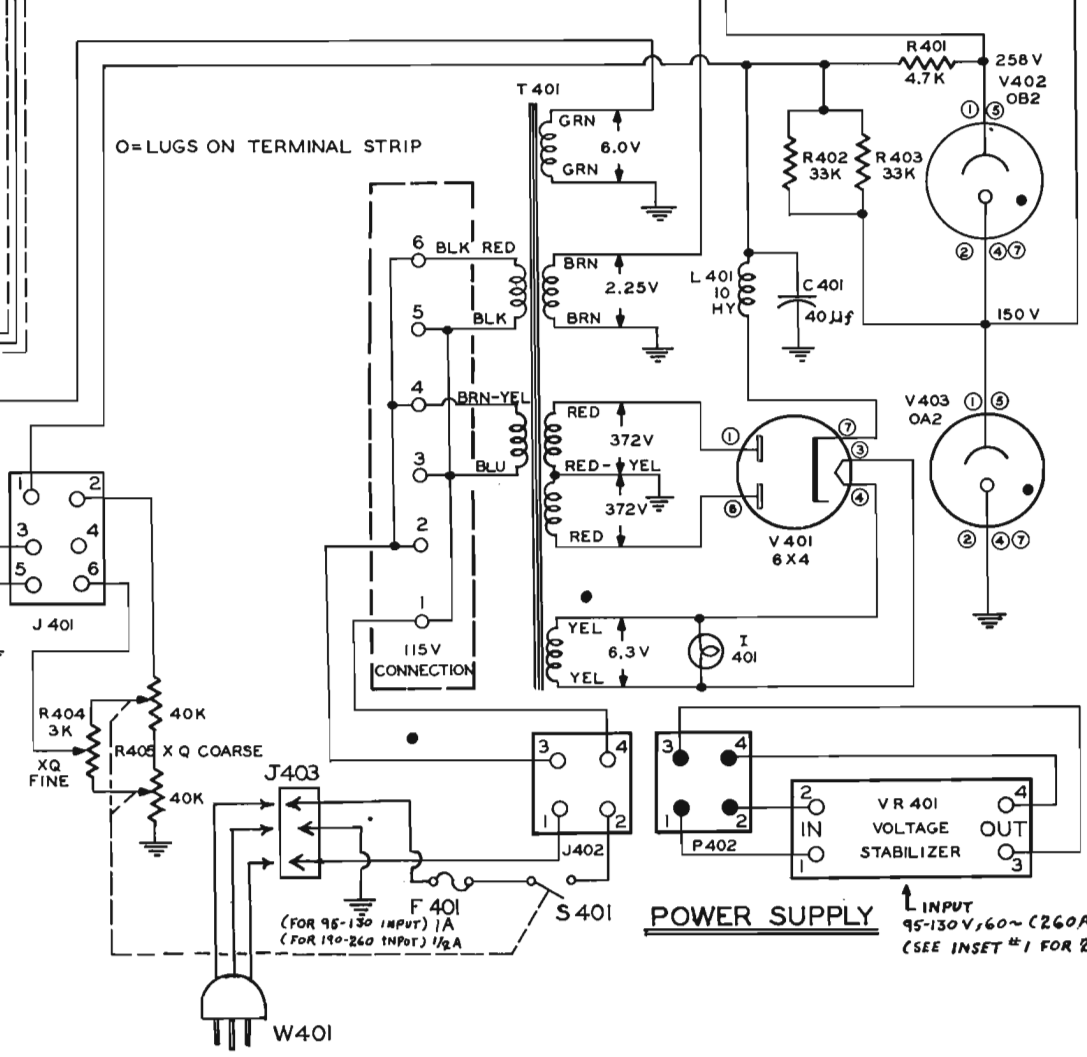
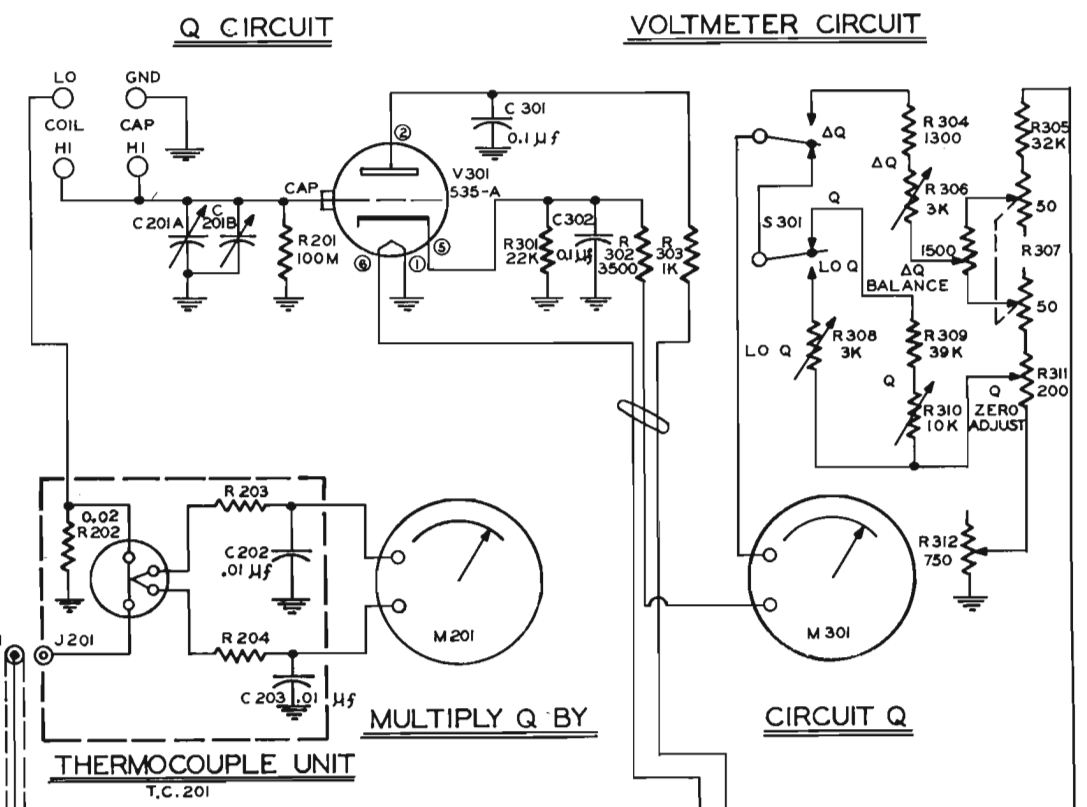
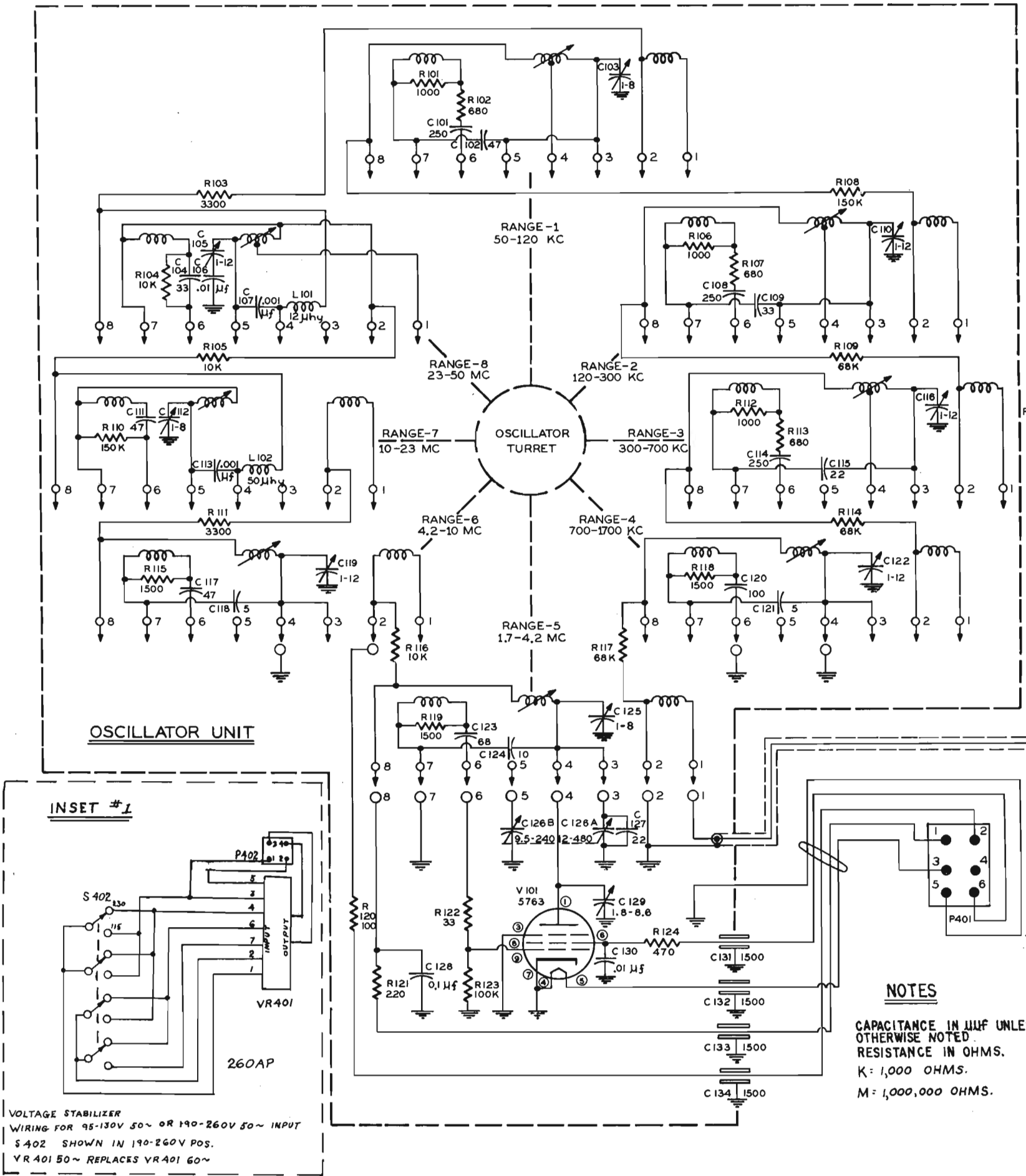

NOTES

CAPACITANCE IN μUF UNLESS OTHERWISE NOTED.

RESISTANCE IN OHMS.

K = 1,000 OHMS.

M = 1,000,000 OHMS.

↑ INPUT
95-130V, 60~ (260A)
(SEE INSET #1 FOR 260AP)